

NATURAL SHADES AND DRAPES



MAY 2024

Product Information Guide

Features	
Natural Shades, Natural Drapes	2
Nature’s Beauty of Natural Shades	3
Material Style Information: Natural Shades, Natural Drapes, and Sliding Panels	4
Size Considerations	
Natural Shades, Natural Drapes	5
Options	
Summary	6
Continuous-Loop Lift: Natural Shades, Cordless Lift: Natural Shades	7
Control Options: Natural Drapes, Fullness: Natural Drapes	8
Liners: Natural Shades and Natural Drapes, Edge Banding and Colors: Natural Shades and Natural Drapes	9
Cut-Outs: Natural Shades, Non-operational Angle Top: Natural Shades	10
Multiple Shades on One Headrail: Natural Shades	11
Bay and Corner Windows	12
Valance: Natural Shades, Deco-Trim Valance: Natural Shades, Valance: Natural Drapes	13
Valance Returns for Standard Valances, Valance: Palisade Valance Only: Natural Shades and Natural Drapes	14
Accent Gimp: Natural Shades, Turned Headrail: Natural Shades, Direct Mount: Natural Shades	15
General Information	
Stack Charts: Natural Shades, Natural Drapes	16
Natural Shades Product Detail	17
Natural Shades Looped Roman Product Detail	18
Natural Shades Cordless Lift Product Detail, Continuous-Loop Lift Product Detail	19
Natural Drapes Product Detail, Cleaning Instructions	20
Warranty	21

PLEASE NOTE:

Photos and illustrations are for inspiration only.
Not all product configurations are available in all countries.

Window blinds with a damaged or loose tension device or retractable cord that fails to fully retract pose a strangulation risk to children. To avoid this potential strangulation risk, consider purchasing cordless products or products with inaccessible cords.

Features

Natural Shades



Bali® Natural Shades are crafted from bamboo reed, slit bamboo, sisal, grass, and jute materials. They add natural color, texture, and dimension to your windows and create a comfortable atmosphere of casual elegance or simple sophistication.

- Standard, Old Style, and Looped Roman shade designs
- Wide selection of colors, textures, and unique weaves
- Cordless lift, continuous-loop lift, and motorized lift available
- 6" valance with horizontally oriented material is standard on shades except for motorized lift and continuous-loop lift
- 9" valance with horizontally oriented material is standard with motorized lift shades and continuous-loop lift

Natural Drapes

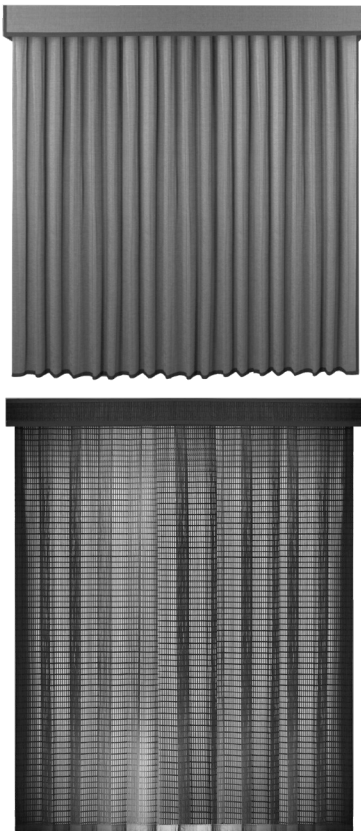

- Natural drapes feature the rolling qualities of drapery in vertically oriented natural shade material
- Features wand control in single or split stack
- Choose from standard fullness (when closed, waves slightly) or a 60% fullness (when closed, features drapery-like appearance)
- Palisade valance included with the drape
- Drape without valance (optional at no charge) is not recommended, as aluminum headrail and hardware will be visible; suggested when ordering wood cornice
 - Wood or fabric cornice is an option in place of valance; see wood cornice or soft treatments product information guide and price list
- Valance and returns will extend ½" further than drape width
- Edgebanding is required and complimentary on the drapes and standard valance
 - Select from 1" solid edgebanding
 - Valance will use matching edgebanding

NOTE: Not available with Blended Grain, Desert Haze, Divan, Faroe, Forage, Rugged Flax, Tarkine, and Walpole.

Features

Nature's Beauty of Natural Shades



There is simply no substitute for the beauty of the materials used in natural shades. The colors and textures of bamboo, reeds, grass, and jute have a distinct character and one-of-a-kind look that synthetic materials can't match.

Unique Characteristics of Natural Shades

Asymmetry

Materials used in natural shades are naturally grown and harvested. Variations in shape, thickness, texture, and grain are to be expected from Mother Nature. While adding personality, these variations create asymmetry in the weave that may alter the appearance of the finished shades. Specifically, you may notice:

- **Uneven Spacing or Gaps**—differences in bamboo or reed shapes and thicknesses can create uneven spacing or gaps in the weave
- **Pattern Changes or Gaps**—varying thickness of grassy materials, tied knots, and splices can create visual disruptions in the weave pattern or gaps in the weave
- **Length Differences**—variations in thickness, bamboo joints, or reed sizes can create length differences from both sides of the shades
- **Bowing or Arching**—different drying rates of bamboo fibers on one side and skin on the other side of the bamboo slat can create a bowing or arching effect on the finished shades

To minimize variations, all materials used are hand selected to comply with strict specifications. These variations are not considered flaws, but rather normal characteristics expected from naturally grown materials.

Color

Evolving with age, the color of bamboo, reeds, jute, grasses, and other natural materials will change slightly. Depending on material composition, they may lighten or darken due to direct sunlight or other climatic conditions. Uncolored or natural materials will experience the most color shift, changing from a green color at harvest to a yellow-brown color over three to six months. Color matching of shades cannot be guaranteed as these are natural reactions to aging.

With character, however, comes inherent natural properties that may influence the appearance of the finished shade. Recognizing and understanding the characteristic traits of natural materials provides more satisfaction and enjoyment once you know why each shade is truly unique!

Stretching/Sagging

The natural elasticity of yarns, combined with the weight of the natural material, may cause shades to stretch or sag from 1" to 1½", and sliding panels to stretch or sag from 1" to 2" after installation. This is particularly noticeable on inside mount shades or shades that extend from ceiling to floor. Ordering shades shorter than needed will help compensate for stretching over time.

Tips

During the shipping process, the natural material may have shifted slightly due to its natural construction, causing slight shortening or uneven edges.

Height—If after installation, the shades are slightly shorter than ordered, grasp the bottom of the shades and gently pull to stretch to the preferred height. Some materials will also stretch by themselves over time.

Uneven Edges—Lightly tap edge of the shades with a flat edge (for example, a ruler) until even.

Frayed Edges—If threads come loose near the edges, use a sharp scissors to trim off stray threads.

Light Control and Privacy

Sheer: Allows the most amount of light into the room for a minimum amount of privacy and a view to the outside. Objects in the room can be seen quite clearly through shades.

Light Filtering: Allows light to gently filter through and provides privacy. Images and shapes may be seen through these shades.

Natural shades may have variations and visual inconsistencies in color, weave, grain, and texture. They may also crack or split, twist or bow, shrink or stretch, and change color over time due to aging, direct sunlight, or other climatic conditions. These unique characteristics are inherent in natural materials and are not considered defects in material or workmanship. Exact color matches cannot be guaranteed.

Features

Material Style Information: Natural Shades, Natural Drapes, and Sliding Panels†

Style Name	Color Name	Color Number	Maximum Fabric Width (inches)	Material Content	Light Control and Privacy**
Alondra	Touch of Blush	50509	96"	Bamboo Reed, Jute, Jute Braid	Sheer to Light Filtering
	Villa	55506			
Antigua	Bahia	25001	96"	Slit Bamboo, Bamboo Reed	Sheer to Light Filtering
	Cinnamon	25003			
	Tiki	25004			
Avonlea	Birdseed	05081	96"	Bamboo Reed, Grass rope	Light Filtering
	Canyon Stone	05084			
Bead	Mojave	42390	96"	Bamboo/Jute/Polyester	Sheer
*Blended Grain	Wild Rice Shimmer	39350	96"	Jute/Bamboo	Sheer
	Sand Dune Shimmer	39351			
Cabo	Lodge	60706	96"	Slit Bamboo/ Bamboo Reed	Sheer to Light Filtering
	Honey Nut	06702			
	Old Hickory	06793			
	Placid	60705			
*Desert Haze	Light Ocean Sand	55330	96"	Jute	Sheer
	Slate Mist	55331			
	Speckled Mojave	55332			
*Divan	Wet Sand	33383	96"	Bamboo	Sheer
*Faroe	Oyster	65090	96"	Grass, Bamboo Reed	Light Filtering
	Twine	65091			
	Spruce	65092			
*Forage	Truffle	10861	96"	Jute/Bamboo	Sheer to Light Filtering
	Portobello	10862			
Framework	Washed Graphite	80722	96"	Bamboo Reed	Sheer
	Hushed Sunlight	80723			
	White	80603			
	Sahara	80727			
Gemma	Restful Tan	80820	96"	Bamboo Slat, Bamboo Reed, Jute	Light Filtering
	Honeynut	80821			
Highpoint	Goldspun	35110	96"	Bamboo Reed, Jute Braid	Sheer
	Brook	35113			
Ivan	Warm Rain	45740	96"	Bamboo, Paper	Sheer to Light Filtering
	Fresh Cotton	45742			
Lagoon	Cadet	85132	96"	Bamboo Reed, Grass	Light Filtering
	Honeynut Cream	85133			
	Slate Mist	85134			
Maywood	Malt	15700	96"	Bamboo Reed	Light Filtering
	Cloud Nine	11502			
Mill Cove	Madras	45200	96"	Bamboo Reed, Grass, Jute Braid	Light Filtering
	Tartan	45201			
Nicaragua	Umber	63659	96"	Slit Bamboo, Bamboo Reed	Light Filtering
	Chocolate	63759			
Papua	Butter	17510	96"	Grass Rope, Bamboo Reed	Light Filtering
	Pestle	17511			
Rattan	White	34480	96"	Bamboo/Jute	Sheer to Light Filtering
	Honeynut Cream	34481			
	Morning Dove	34482			
Ridge	Beachcomber White	15960	96"	Bamboo Reed/Grass/Jute Braid	Sheer to Light Filtering
	Sandbar	15968			
Rila	Forest Fawn	75800	96"	Bamboo Reed, Yarn	Sheer to Light Filtering
	Burlap Beige	75810			
*Rugged Flax	Parchment	73310	96"	Paper Yarn/Bamboo Stick/Poly Thread	Sheer to Light Filtering
	Graphite Sea Glass	73311			
	Sea Glass	73312			
Seashell	Deep Lagoon	37340	96"	Bamboo Slat/Poly Thread	Sheer to Light Filtering
	White	37341			
	Ocean Smoke	37342			
	Soft Blush	37343			
*Tarkine	Mulberry	03269	96"	Jute	Sheer
	Ocean Sand	03370			
*Walpole	Cypress	60040	96"	Bamboo Reed	Sheer
Zenon	Bold Roast	34587	96"	Slit Bamboo, Bamboo Reed, Grass Rope	Sheer to Light Filtering
	Deep Taupe	40589			

*Not available in natural drape

**All fabrics have similar streetside appearance

†See sliding panels product information guide for more information

Size Considerations

Natural Shades

	Width		Height	
	Minimum (inches)	Maximum (inches)	Minimum (inches)	Maximum (inches)
Old Style and Standard Roman	10 outside mount 10½ inside mount	96 single 144 multiple	12	120
Looped Roman	12 outside mount 12½ inside mount			120
Continuous-Loop Lift	24 outside mount 24½ inside mount			108
Cordless Lift	12 outside mount 12½ inside mount	96 single 144 multiple	12	86 see price charts
Multiple Shades on One Headrail	20½	144	12	See price charts
Motorized Lift	18 outside mount 18½ inside mount	Determined by square feet. See motorization product information guide for more details.		

Depth Requirements for Inside Mount

Type of Shade	Headrail Dimensions (inches)	Minimum Depth Mount (inches)		Flush with Casing (inches)	
		Partially recessed headrail in window casing/molding	Fully recessed headrail in window casing/molding	Standard valance:	Standard valance:
Continuous-Loop Lift Motorized Lift	5/8 x 2¼	¾	¾	Standard valance: 3⅞	
Cordless Lift	1½ x 2½			Standard valance: 2⅞	
Turned Headrail	1½ x 5/8			Standard valance: 1⅞ standard Roman; 1 old style Roman	

Natural Drapes

	Width		Height	
	Minimum (inches)	Maximum (inches)	Minimum (inches)	Maximum (inches)
Standard Drapery Fullness	16 outside mount 17 inside mount	192	20	96
60% Drapery Fullness				

NOTE: Minimum surface for outside mount: 3".

Depth Requirements for Inside Mount

Type of Shade	Headrail Dimensions (inches)	Minimum Depth Mount (inches)		Flush with Casing (inches)	
		Partially recessed headrail in window casing/molding*	Fully recessed headrail in window casing/molding	Standard valance:	Standard valance:
Wand Control	7/8 x 1½	Standard drapery fullness 60% drapery fullness	3⅞ 4½	8	

*Shown with valance; aluminum headrail is covered by valance.

NOTE: Standard inside mount deduction is ½" for all control types.

Options

Summary

The following is a list of options for natural shades. Most options are available in all styles and colors. Limitations will be based on fabric width and fabric type. See detailed descriptions on the following pages. For surcharges and pricing, refer to price charts.

	Standard Roman	Old Style Roman	Looped Roman
Standard	•	•	•
Cordless Lift	•	•	
Continuous-Loop Lift	•	•	•
Motorized Lift	•	•	
Angle Top	•		
Cut-Outs	•	•	
Multiple Shades on One Headrail	•	•	•

No Charge Options: Natural Shades

- Direct mount (no installation mounting brackets)
- Side mount brackets available up to 42" wide
- Bay or corner window
- Clear cord cleats: standard
- Hem options: standard hem
- Hold down brackets^{††}
- Projection brackets: 3 1/8"
- Returns 2" short
- Turned Headrail
- Valances included at time of order:
 - Standard 6": cord lift; bottom up/top down; and cordless
 - Standard 9": continuous-loop lift and motorized lift
 - No valance: optional

Surcharge Options: Natural Shades

- Continuous cord/chain loop
- Cord cleats: antique or solid brass
- Cord winder
- Cordless lift
- Cut-outs
- Edge banding[†]
- Liners
- Motorized lift
- Multiple shades on one headrail
- Specialty Shapes
 - Angle Top
- Valance options:
 - Standard 9"
 - Palisade 6"
 - Palisade 9": all control types
 - Deco-trim valance 9"
- Wood cornice: see cornices and valances product information guide

No Charge Options: Natural Drapes

- Control types
 - Wand control
- Ceiling mount brackets
- Edge banding[†]
- Stack right, left, or split
- Fullness: standard
- Valances:
 - Palisade 6"
 - Horizontal or vertical orientation
 - Palisade 9"
 - Horizontal or vertical orientation
 - Deco-trim valance 9"
 - Horizontal material orientation
 - No valance: optional

Surcharge Options: Natural Drapes

- Fullness: 60%
- Liners
- Wood cornice: see cornices and valances product information guide

[†]Edge banding: Optional on shades or valances on most fabrics with horizontally oriented material; required on Sliding Panel, Natural Drape, and valances with vertically oriented material. Complimentary when required.

^{††}Hold down brackets: Only available at time of order. Cannot be retrofitted. Not available for shades with edge banding.

Natural shades may have variations and visual inconsistencies in color, weave, grain, and texture. They may also crack or split, twist or bow, shrink or stretch, and change color over time due to aging, direct sunlight, or other climatic conditions. These unique characteristics are inherent in natural materials and are not considered defects in material or workmanship. Exact color matches cannot be guaranteed.

Options

Continuous-Loop Lift: Natural Shades

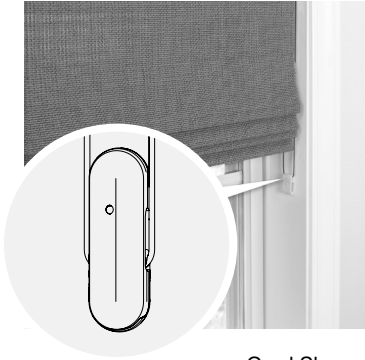

Cord Shown

- **For surcharge, see price charts**
- Available on Standard, Old Style, and Looped Roman shades
- Continuous-loop lift raises and lowers the shade and is color coordinated to the shade material
 - Shades under 30 square feet have color-coordinated cord
 - Shades over 30 square feet will use a nickel-plated steel bead chain loop in place of cord
 - When ordering different size shades for the same room, specify if bead chain is preferred for all shades
- Allows for easier operation of larger shades
- 9" valance is standard with the continuous-loop lift option; (6" valance not available)

Cordless Lift: Natural Shades



- **For surcharge and size restrictions, see price charts**
- Available on Standard and Old Style Roman shades
- Cordless shades offer a safer alternative for homes with children and pets
- Easy to use: to lower shade, pull down; to raise, simply guide the shade into the desired location by gently lifting or lowering with the color-coordinated wooden bottom rail at a 45° angle.
- Not available with cut-outs, deco-trim, deco-pocket hems, or angle top shades
- Standard return size is 2 $\frac{3}{8}$ "

Motorized Lift: Natural Shades

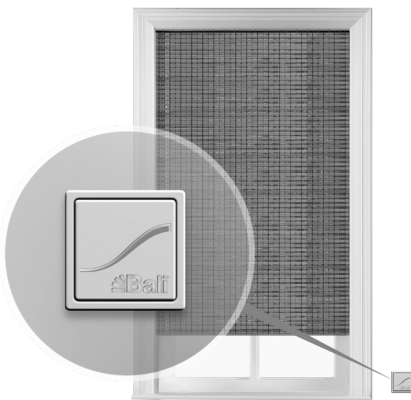

- **Refer to motorization product information guide for additional options, sizes, and pricing**
- Window treatments can be operated from virtually anywhere in the home
- Provides easy operation of hard-to-reach or large window coverings
- Efficiently manages energy (heat gain and loss)
- Operate multiple window treatments simultaneously or individually
- A safer alternative to accessible cords that are traditionally used to operate window coverings; ideal for homes with children and pets
- Easily integrated with home automation systems
- Low voltage motorization requires no costly electrical hard-wiring
- Multiple control and power options available

Details

- Motor located on the right underside of the headrail
- Multiple controls and power options available
- Available on standard and old style Roman
- Available with 9" valance only; no valance is optional
- Multiple shades on one headrail available; each panel will have a motor and power source
- Not available on looped Roman
- Available with bottom corner and bottom center cut-outs

NOTE: Motorization components and accessories have a five-year limited warranty, excluding batteries.

Options

Control Options: Natural Drapes



Wand Control, no charge (default control type)

- Ivory fiberglass wand positioned behind drape
- Stack right, left, or split
- Split stack will have two wands

Wand Control Chart

Finished Blind Length (inches)	Wand Length (inches)
Up to 30	12
30 ¹ / ₁₆ to 48	24
48 ¹ / ₁₆ to 77	36
77 ¹ / ₁₆ to 92	48
92 ¹ / ₁₆ to 96	60

Fullness: Natural Drapes



Standard Fullness Right Stack

- **For surcharges, see price charts**
- Standard fullness (when closed, waves slightly)
- 60% fullness (when closed, features drapery-like appearance)
- Palisade valance included at time of order; see valance options for available styles



60% Fullness Right Stack

Options

Liners: Natural Shades and Natural Drapes

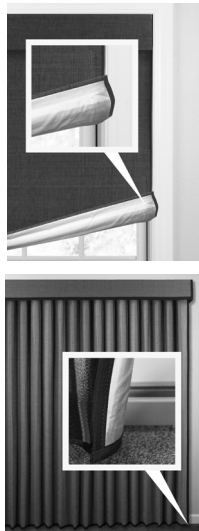

- For surcharges, see price charts
- Liners are 100% polyester
- Available up to 96" wide on shades and 192" on drapes
- Privacy and room-darkening liner colors available
- All liners are neutral to the street
- Liner reversal available upon request

Privacy Liner

A privacy liner is a good choice for dining rooms, living rooms, and other semi-private areas, subduing the light that enters a room. Small pinholes of light may be visible through shades with privacy liners due to the attached cord rings; see room-darkening liners for enhanced light control. Objects appear as silhouettes from the outside.

Room-Darkening Liner

This liner blocks most incoming light and provides complete privacy. Ideal for bedrooms and media rooms.

Colors	Privacy Color Number	Room-Darkening Color Number
Cocoa	2297	6297
Taupe	2659	6659
Sand	2701	6701
Seal	2012	6012
Snow White	2909	6909

Edge Banding and Colors: Natural Shades and Natural Drapes



- For surcharge, see price charts
- Edge banding adds a framed color accent and can also eliminate material fray on edge of shade
- On cordless, edgebanding will only be on sides of shade
- 1" fabric banding is applied to sides and bottom of shade and valance
- Deco-trim valance may be ordered with edge banded shades, valance will not have edge banding
- See chart for colors
- Edge banding not available on deco-trim, angle top shades, cut-outs, or with hold down brackets

Natural Drapes

- 1" edge banding required on top and bottom of drapes: **no charge**
- Optional 1" edgebanding available on drape sides: **no charge**
- Lined drapes require edge banding on all four sides
- Use chart below for colors

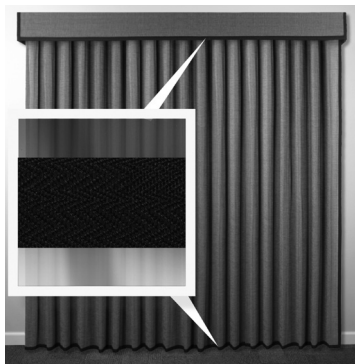

Edge Banding	1" Color Number
Black	7000
Chocolate	7006
Cocoa	7001
Dark Beige	7005
Gray	7176
Light Sage	7173
Mink Gray	7174
Muslin	7172
Smoke	7175
Snow White	7170
Taupe	7008
Toffee	7002
Vanilla	7171

Options

Cut-Outs: Natural Shades

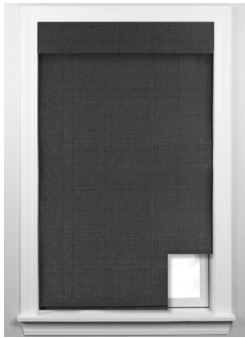

- For surcharge, see price charts
- Available with standard and old style Roman shades
- Bottom corner cut-out (diagram A):
 - Maximum width: 6" cut-out
 - Any height (up to the headrail)
- Bottom center cut-out (diagram B):
 - Maximum height: 5" cut-out
 - Maximum width must leave 3" on each side of the cut-out
- Not available with: hold down brackets, edge banding, cordless lift, continuous-loop lift, or looped Roman shades

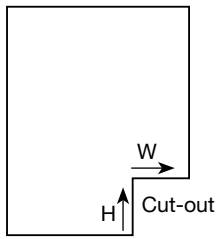

Diagram A

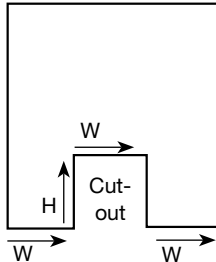

Diagram B

Non-operational Angle Top: Natural Shades



For surcharges, see options pricing

- 3-day manufacturing time does not apply
- For angle top shades, supply all four measurements (A, B, C, D) as shown in the diagram below
- Shades will raise only to the bottom edge of the valance; the upper angled portion of the shades and valance cannot be opened and closed
- 6" (15.3 cm) and 9" (22.9 cm) standard valance only
- Valance requires gimp trim at the top edge by the headrail (A)
- Valance returns are not available
- Available as non-operational only
- Available as Standard Roman only

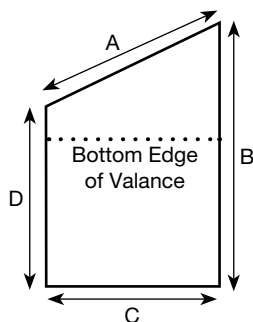

Minimum Width	18" (45.8 cm) (outside mount) 18½" (47.0 cm) (inside mount)
Maximum Straight Width	60" (152.4 cm) (outside mount) 60½" (153.7 cm) (inside mount)
Minimum Height	12" (30.5 cm)
Minimum Height (short side)	7½" (19.1 cm)
Maximum Height	86" (218.44 cm)
Maximum Degree of Angle	60°

Measuring Outside Mount:

1. Measure exact width and height of area to be covered. It is recommended that shades overlap window frame or opening by 1½" (3.9 cm) on each side.
2. Measure height of opening on left side and mark this dimension "left". Allow for overlap as desired: 1½" (3.9 cm) on top and bottom is recommended.
3. Measure height of opening on the right side and mark this dimension "right". Allow for same overlap as left side.
4. Factory will determine the angle from these three dimensions.

Options

Multiple Shades on One Headrail: Natural Shades

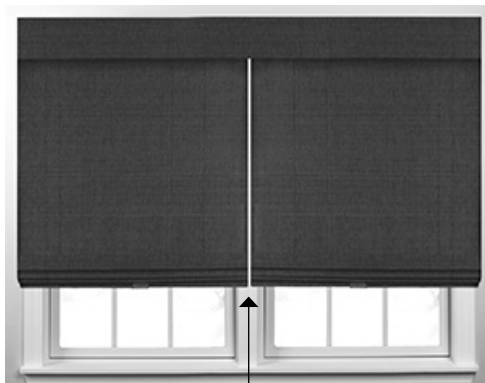

- For surcharges, see price charts

How to Measure

1. Measure overall width of area to be covered.
2. Measure width of the area each shade is to cover; measure and specify left shade first, continuing to the right.

NOTE: Minimum of 1/2" between shades for operating clearance.

3. Total width of all shades, plus clearance (gap), must equal the overall headrail width.
4. Use standard inside or outside measuring directions for height.
5. For patio doors, measure height to within 1" of the floor either from the ceiling or a point high enough above door to provide clearance; cords should be on outside edges of shades; outside mount (wall) installation is recommended for patio doors.

- Shades operate separately
- Controls can be on the right or left at no charge
 - Standard for two-on-one headrail: left panel—left control; right panel—right control
 - Standard for three-on-one headrail: left panel—left control; middle panel—common lift; right panel—right control
- Cordless and motorized lift
 - Two-on-one and three-on-one available—no charge
- Continuous-loop cord lift
 - Two-on-one available with control positions to the outside
 - Three-on-one available if the lift control is on combined on all three shades; horizontal material alignment between panels is not guaranteed
- Liner options available
- Edge banding is available—will be attached around each panel
- Shades up to the maximum material width will have a continuous valance
- Shades over maximum material width will have a valance with each panel which are butted in between each panel gap
- Palisade valance will not be spliced at the same dimensions as the multiple blinds; palisade valances will be spliced evenly

NOTE: Horizontal oriented valances over 96" will be spliced in one to three places and will not align with shade panels. Vertically oriented material will be one continuous piece. Hardwood frame will be spliced at 94" with returns and 95" without returns.

Options

Bay and Corner Windows

- Available on Standard and Old Style Roman shades
- Bay and corner shades are used to butt two shades together in a corner window
- Depending on the angle, some corner shades cannot be raised to the same height
- Bay and corner shades not available with hold down brackets, Looped Roman shades, and multiple shades on one headrail
- Horizontal and vertical alignment can't be guaranteed
- Priced as standard shades, no additional surcharge

- Headrails will not be mitered
- Standard valances will not be mitered
- Palisade valances will be mitered

NOTE: Manufacturer will take appropriate deduction for corner/bay windows. If deductions are not required, do not order as corner/bay.

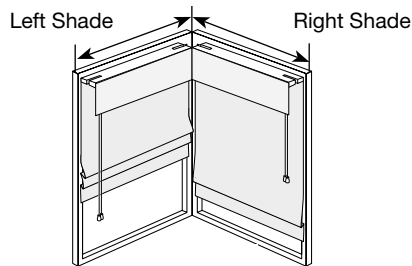

Shades will not raise to same level

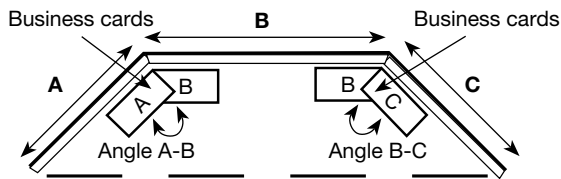

Front View

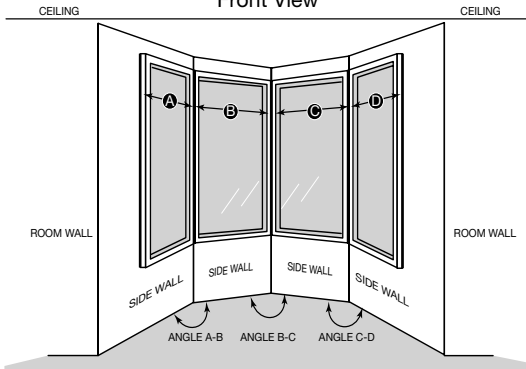

Front View

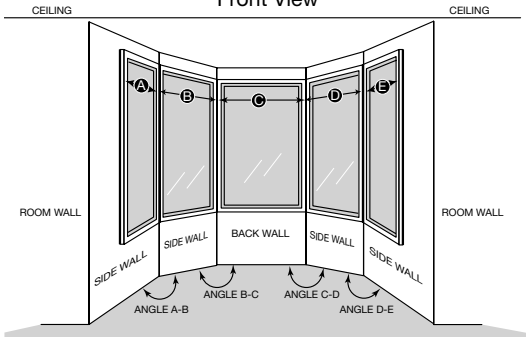

Measuring Information

Corner Window

Measure:

Width of each window from corner to the point you would like to cover.

Three-Sided Bay Window

Measure:

A and C: Width of side windows from the corners to the point you would like the blind to cover.

B: Width of the center window from corner to corner.

Angle A-B: Angle between windows (A) and (B).

Angle B-C: Angle between windows (B) and (C).

Measure bay angle using protractor or angle finder, or use two business cards in bay corner as illustrated and fax to customer service.

Four-Sided Bay Window

Measure:

A and D: Width of side windows from the corners to the point you would like the blind to cover.

B and C: Width of each window from corner to corner.

Angle A-B: Angle between windows (A) and (B).

Angle B-C: Angle between windows (B) and (C).

Angle C-D: Angle between windows (C) and (D).

Measure bay angle using protractor or angle finder, or use two business cards in bay corner as illustrated and fax to customer service.

Five-Sided Bay Window

Measure:

A and E: Width of side windows from the corners to the point you would like the blind to cover.

B, C, and D: Width of each center window from corner to corner.

Angle A-B: Angle between windows (A) and (B).

Angle B-C: Angle between windows (B) and (C).

Angle C-D: Angle between windows (C) and (D).

Angle D-E: Angle between windows (D) and (E).

Measure bay angle using protractor or angle finder, or use two business cards as illustrated and fax to customer service.

Options

Valance: Natural Shades

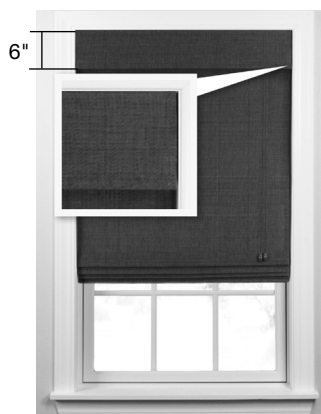

Standard Valance Horizontal Orientation



Palisade Valance Option B Shown

Cordless no charge options

- 6" valance with shade
- No valance is optional; unfinished headrail and hardware are visible

Continuous-loop lift and motorized lift no charge options

- 9" valance with shade (6" valance is not available)

Additional valance information

- Edge banding will be applied to the sides and bottom of the valance if option is chosen for complete finished shades
- Liner can be added to the valance; must specify privacy or room-darkening liner and color; see price charts for surcharge

Control Type/ Shade Options with Standard Valance	Full Recess Depth Including Valance (inches)	Standard Return Width Outside Mount (inches)	Standard Return Width Inside Mount (inches)	Minimum Return Width (inches)	Maximum Return Width (inches)
Cordless Lift	2 ⁷ / ₁₆	2 ⁷ / ₁₆	2 ⁷ / ₁₆	1 ¹ / ₂	3 ¹ / ₂
Continuous-Loop Lift	3 ³ / ₁₆	2 ¹³ / ₁₆	2 ¹ / ₄	1 ¹ / ₂	3 ¹ / ₂
Motorized Lift*	3 ³ / ₁₆	2 ¹³ / ₁₆	2 ¹ / ₄	1 ¹ / ₂	3 ¹ / ₂

*See motorization product information guide for more details.

- Special 2" valance return **length**: available upon request
- No liner or edge banding on valance returns

Valance: Natural Drapes

- No charge for palisade valance at time of order (must select option)
- Liner is required for vertically oriented palisade valance
- No valance is optional; aluminum headrail and hardware are visible
- Valance return height will match valance height option chosen

Deco-Trim Valance: Natural Shades

Seascape



This design is scaled to the width of the shade.

Dentil



This design will repeat with the width of the shade.

Cathedral



This design will repeat with the width of the shade.

Horizon



This design is scaled to the width of the shade.

• For surcharge, see price charts

- Distinctive valance designs with accent gimp
- Deco-trim valance designs are cut into the valance of the shade to a depth of approximately 2¹/₂"
- 9" deco-trim valance is measured from the top of the headrail to the lowest point
- Accent gimp must be selected with deco-trim valance
- Available with 9" valance only

Options

Valance Returns for Standard Valances

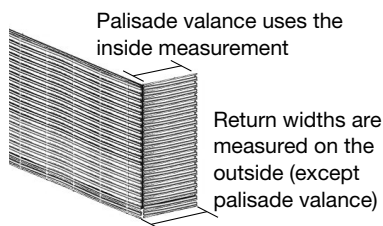

Window depths vary considerably depending on the age and style of the window. **Always** measure the window depth, regardless of the type of window treatment the client is considering. Knowing the depth when the order is placed can help prevent costly errors.

To calculate the return width, use this formula:

[standard return width] minus [client window depth] = special return width to order for inside mount blind

Valance: Palisade Valance Only: Natural Shades and Natural Drapes

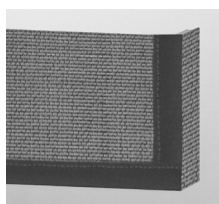

Option A

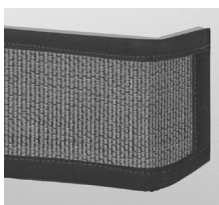

Option B

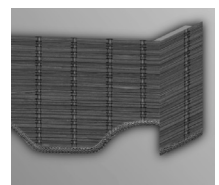

Option C

Palisade valance only

- No charge option for natural drape at time of order

Natural material is mounted to a North American hardwood frame with mitered corner returns that attach separately. Valance upgrade options provide stable returns and a clean, uniform appearance.

- Valance can be ordered for use alone or to complement other window treatments
- Valance material is attached to a hardwood frame; includes mounting brackets (standard, ceiling, or projection brackets)
- Valance returns are available (must be specified at the time of the order)
- Valance returns are standard on outside mount natural palisade valance based on headrail depth

Control Type/ Shade Options with Palisade Valance	Full Recess Depth Including Valance (inches)	Minimum Return Width (inches)	Inside Measurement			
			Return Width Inside/Outside Mount—Standard Mounting Brackets (inches)	Return Width Inside/Outside Mount—2" Extension Brackets (inches)	Return Width Inside/Outside Mount—2 5/8" Extension Brackets (inches)	Return Width Inside/Outside Mount—3 1/2" Extension Brackets (inches)
Continuous-Loop Lift	4 1/2	1 1/2	3 5/16	4 1/2	5 1/8	6
Motorized Lift*	4 1/2	1 1/2	3 5/16	4 1/2	5 1/8	6
Cordless Lift	2 7/8	1 1/2	2 7/8	3 5/8	4 7/8	5 1/8
Drape	8	2	6 1/2	N/A	N/A	N/A

*See motorization product information guide for more details.

- Valances over maximum material width will be butted
- Edge banding is available on 6" or 9" horizontal or vertical oriented material; not available on deco-trim
- No liner or edge banding on valance returns

Options:

- 6" or 9" valance with horizontally material orientation; edge banding is optional (6" not available with motorized lift and continuous-loop lift).
- 6" or 9" valance with vertical material orientation; 1" edge banding top and bottom mandatory (6" not available with motorized lift and continuous-loop lift).
- 9" deco-trim valance; no vertical orientation option (must select accent gimp).
- Wood cornice: See cornices and valances product information guide.

NOTE: Horizontal oriented valances over 96" will be spliced in one to three places and will not align with shade panels. Vertically oriented material will be one continuous piece. Hardwood frame will be spliced at 94" with returns and 95" without returns.

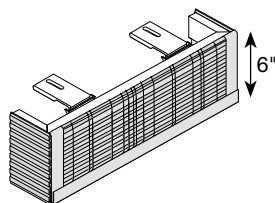

Valance less than 96"

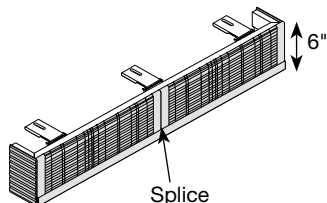

Valance over 96"

Options

Accent Gimp: Natural Shades

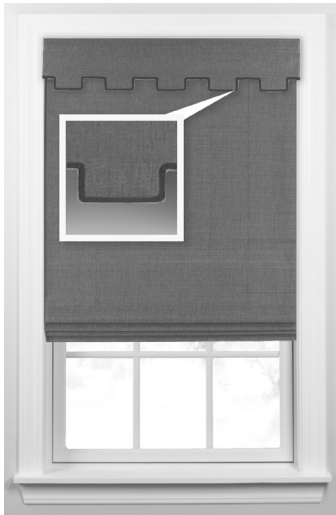

- **For surcharges, see price charts**
- Required with 9" deco-trim valance; optional on other horizontal material orientation valances and standard hems
- Not available with vertically-oriented material



NOTE: Must choose accent gimp color when a deco-trim style has been selected for the valance or hem.

Black	156	Rock Gray	399
Chocolate	04	Tender Taupe	103
Cream	715	Toffee	296
Dark Beige	350	White	417

Turned Headrail: Natural Shades

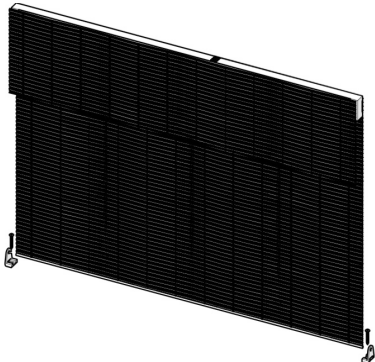

- **No charge**
- Headrail turned 90 degrees to allow for a smaller inside mount shade or for use on French doors
- Available as inside or outside mount; headrail mounted by placing mounting screws through headrail directly into mounting surface
- Minimum depth required: 3/4" (2.0 cm)
- Available as Standard and Old Style Roman with standard cord lift
- 6" (15.3 cm) standard or 9" (22.9 cm) deco-trim valance available options; see price charts for surcharge
- Available as non-operational only
- **Valance returns are not available**

Direct Mount: Natural Shades

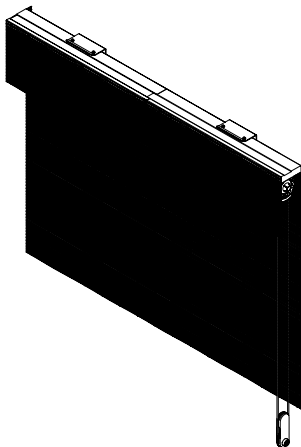

- **No charge**
- Option to remove metal mounting plates on shades with a wood headrail and mount directly to mounting surface
- Shade will come factory predrilled mounting holes in the wood headrail
- Available as inside or ceiling mount, headrail mounted by placing mounting screws through the headrail directly into the mounting surface.
- Minimum depth required : 3/4"
- Available on motorized lift, continuous cord loop, bay and corner windows
- Not available on cordless lift
- 6" and 9" standard and 9" deco valance available
- Returns are available

General Information

Stack Charts: Natural Shades

NOTE: For shades, stack height is measured from the top of the headrail to the lowest point of the shades when completely raised. Stack heights are approximate and will vary by material.

Stack Height: Natural Shades

	Height of Shade up to (inches)	Standard Hem	
		No Liner (inches)	Privacy or Room-Darkening Liner (inches)
Continuous-Loop Lift Motorized Lift • Standard Roman • Old Style Roman	30	9¾ to 10	9¾ to 10¼
	50	10¼ to 10¾	10½ to 11
	70	11 to 11¼	11¼ to 11½
	90	11½ to 11¾	11¾ to 12
	110	12 to 12¼	12¼ to 12½
	120	12½ to 12¾	12¾ to 13
Continuous-Loop Lift • Looped Roman	30	10¾ to 11	10¾ to 11¼
	50	11¼ to 12¼	11½ to 13¼
	70	12½ to 13¾	13½ to 14¼
	90	14 to 14½	14½ to 15¼
	110	14¾ to 15¼	15½ to 16¼
	120	15½ to 15¾	16½ to 16¾
Cordless Lift • Standard Roman • Old Style Roman	30	8¾ to 9¾	8¾ to 10
	50	10¼ to 10½	10¼ to 10½
	70	10¾ to 11	10¾ to 11¼
	90	11¼ to 11½	11½ to 11¾
	110	11¾ to 12	12 to 12¼
	120	12 to 12½	12¼ to 12½

Stack Charts: Natural Drapes

NOTE: For drapes, stack width is measured from the outside of the drapes to the inside of the drapes. Stack widths are approximate and will vary by material.

Natural Drapes 10% Standard Fullness Stack Chart

Wand Control				
Width of Shade up to (inches)	Single Stack		Split Stack, Each Side	
	Minimum Range Thinner Fabrics (inches)	Minimum Range Thicker Fabrics (inches)	Minimum Range Thinner Fabrics (inches)	Minimum Range Thicker Fabrics (inches)
27	6½ to 9	9 to 12	5½ to 7½	7½ to 9½
40	9 to 11	12 to 15	7½ to 9	9½ to 11½
51	11 to 14	15 to 18	9 to 10½	11½ to 13½
63	14 to 16	18 to 21	10½ to 12	13½ to 15
75	16 to 18	21 to 24	12 to 13½	15 to 16½
88	18 to 20	24 to 27	13½ to 14½	16½ to 18
102	20 to 22	27 to 30	14½ to 15	18 to 19½
115	22 to 24	30 to 33	15½ to 16½	19½ to 21
128	24 to 26	33 to 36	16½ to 18	21 to 22½
141	26 to 28	36 to 39	18 to 19	22½ to 24
157	28 to 30	39 to 43	19 to 21	24 to 25
170	30 to 32	43 to 46	21 to 22	25 to 26
183	32 to 35	46 to 49	22 to 23	26 to 27
192	35 to 37	49 to 53	23 to 24	27 to 28

Natural Drapes 60% Fullness Stack Chart

Wand Control				
Width of Shade up to (inches)	Single Stack		Split Stack, Each Side	
	Minimum Range Thinner Fabrics (inches)	Minimum Range Thicker Fabrics (inches)	Minimum Range Thinner Fabrics (inches)	Minimum Range Thicker Fabrics (inches)
27	8 to 12	11 to 16	7 to 9	9 to 12
40	12 to 15	16 to 21	9 to 11	12 to 14
51	15 to 18	21 to 25	11 to 13	14 to 16
63	18 to 21	25 to 30	13 to 15	16 to 18
75	21 to 24	30 to 35	15 to 17	18 to 20
88	24 to 27	35 to 40	17 to 19	20 to 22
102	27 to 30	40 to 44	19 to 21	22 to 25
115	30 to 34	44 to 49	21 to 23	25 to 28
128	34 to 38	49 to 54	23 to 25	28 to 30
141	38 to 42	54 to 60	25 to 27	30 to 32
157	42 to 46	60 to 66	27 to 29	32 to 36
170	46 to 49	66 to 71	29 to 31	36 to 38
183	49 to 52	71 to 75	31 to 33	38 to 40
192	52 to 55	75 to 80	33 to 36	40 to 43

General Information

Natural Shades Product Detail

Standard Roman

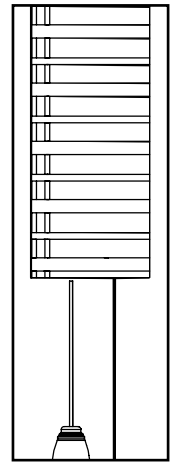
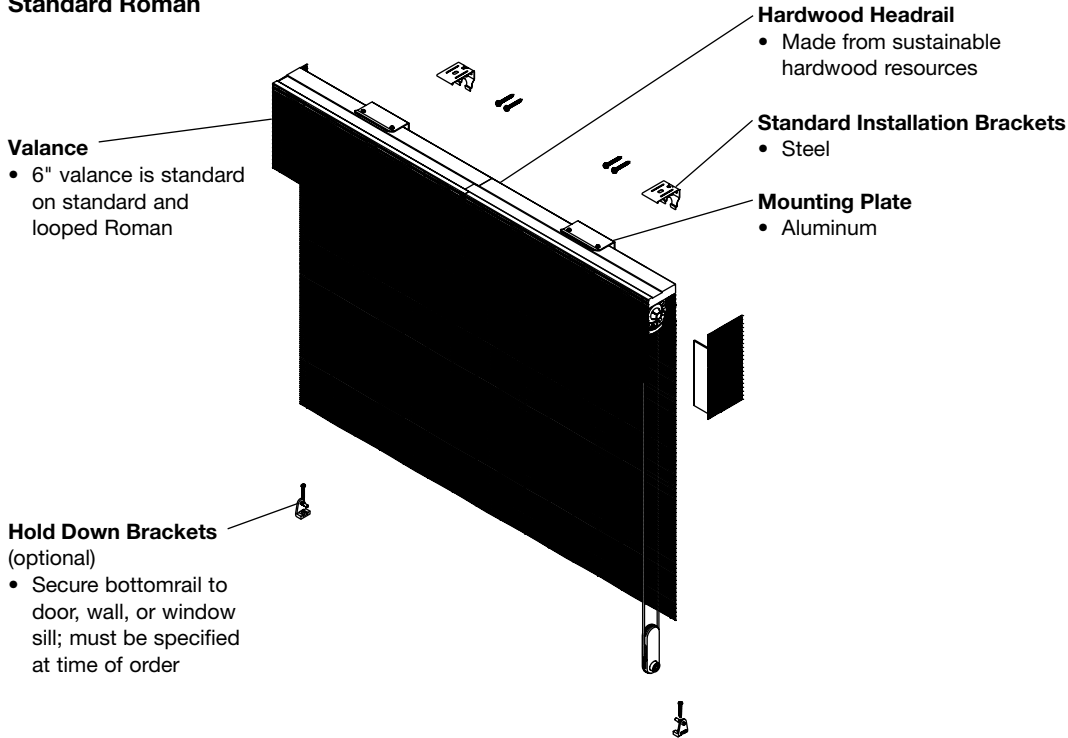

Old Style Roman

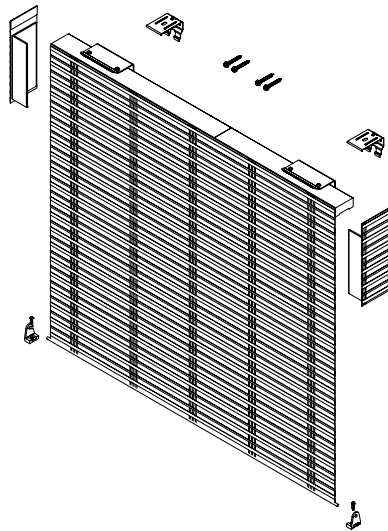

Standard Roman Turned Headrail

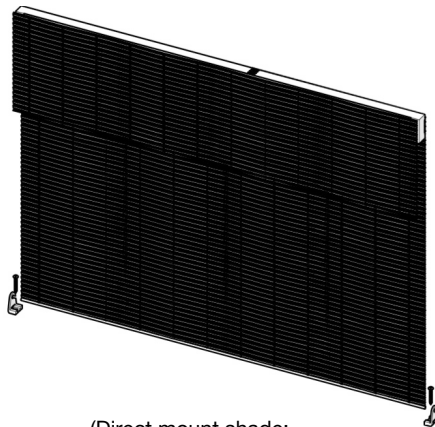

(Direct mount shade; no returns available)

General Information

Natural Shades Looped Roman Product Detail

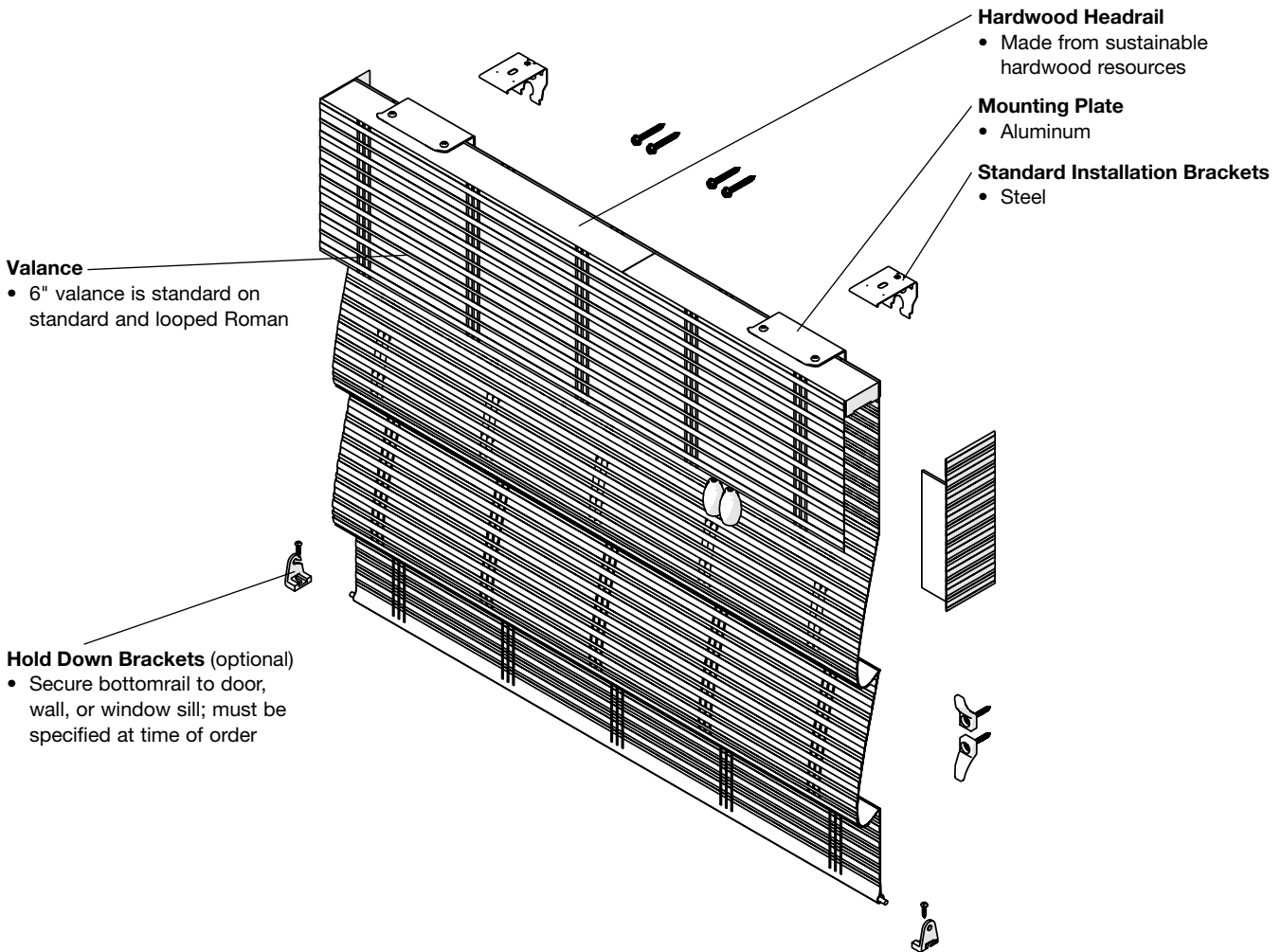

General Information

Natural Shades Cordless Lift Product Detail

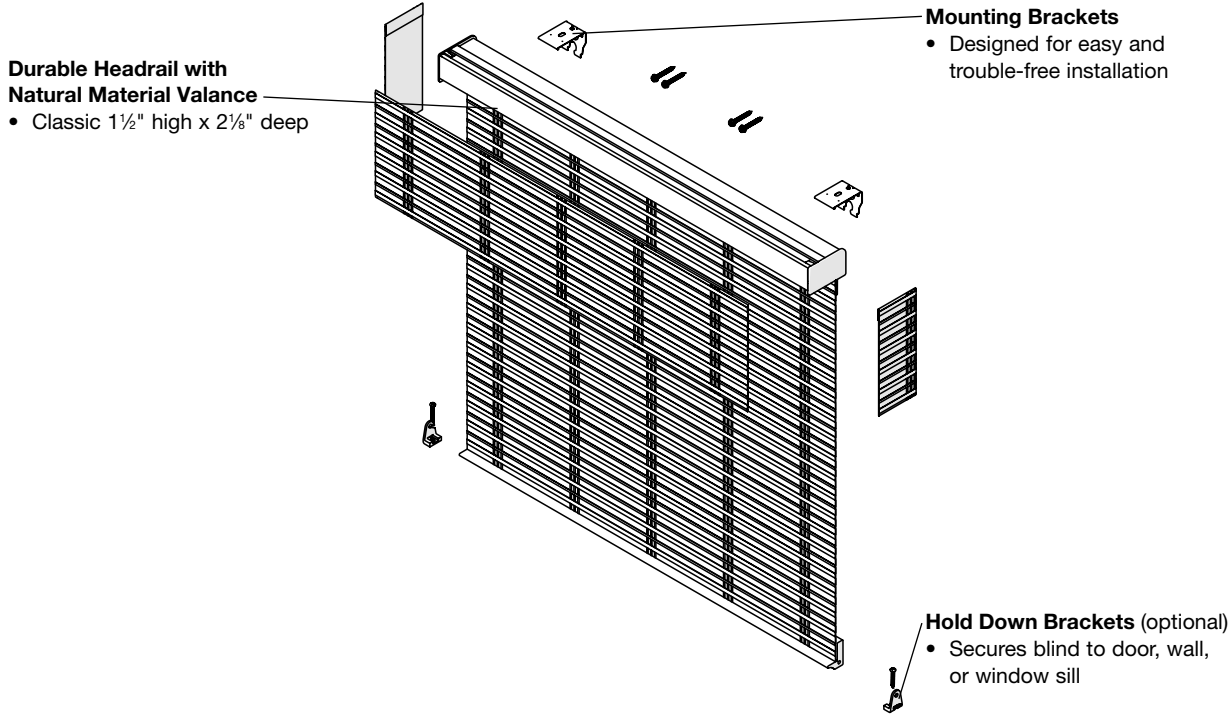

Natural Shades Continuous-Loop Lift Product Detail

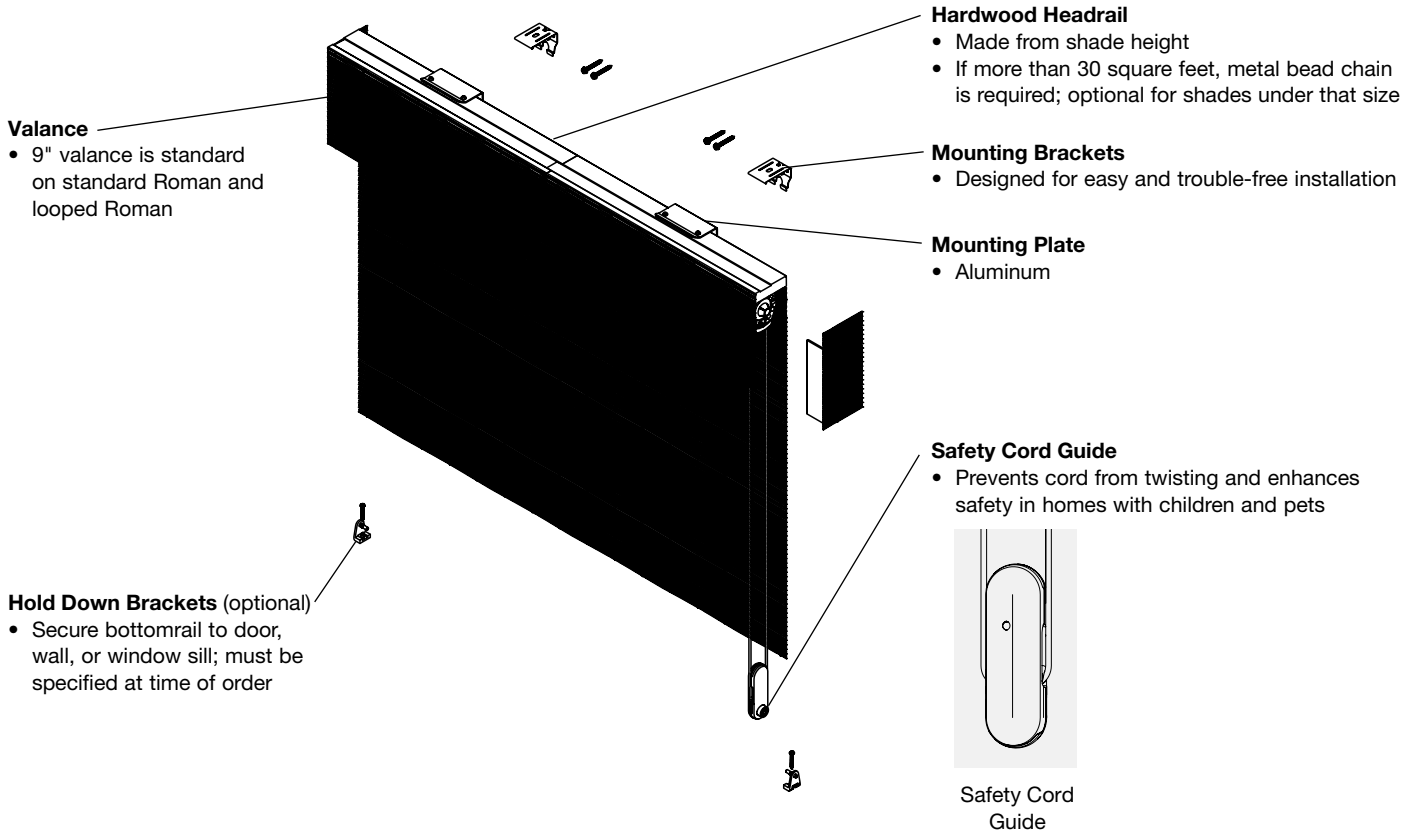

General Information

Natural Drapes Product Detail

Wand Control

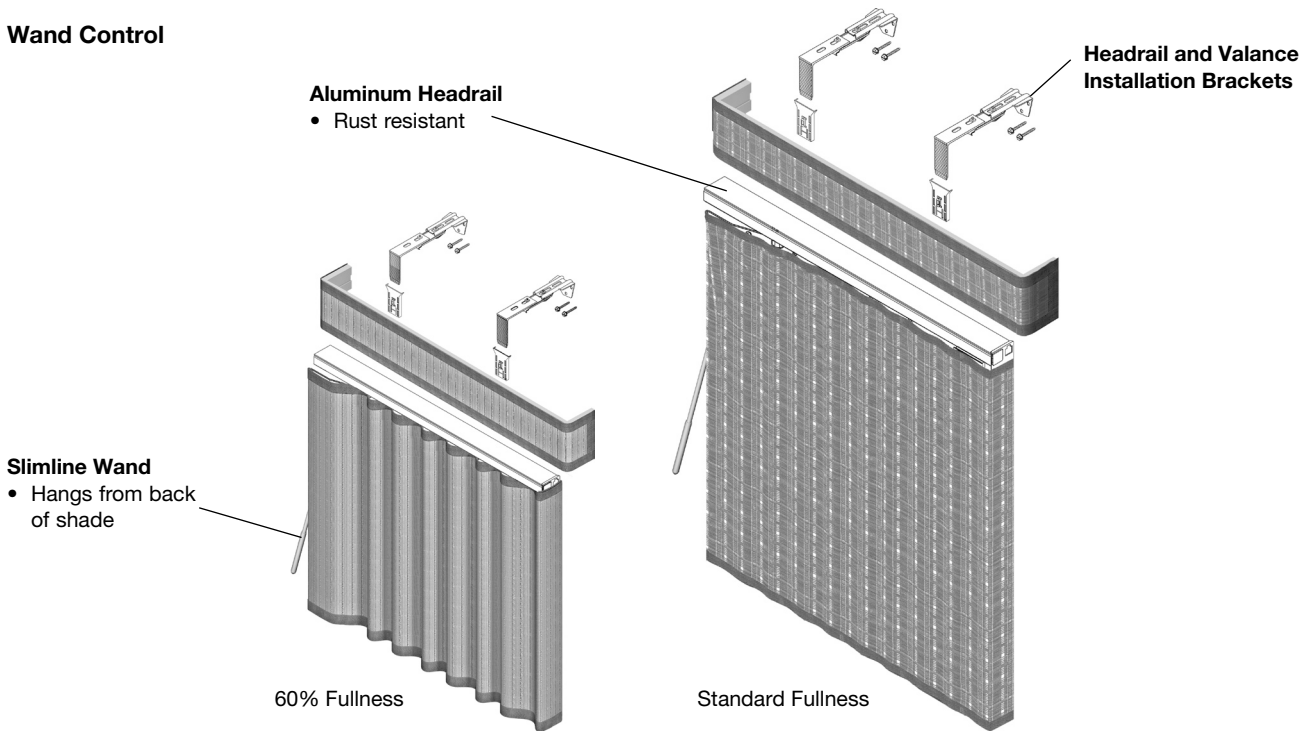

NOTE: Natural materials are vertically oriented on the natural drapes and valance.

Cleaning Instructions

Occasional light vacuuming with a brush attachment should keep shades clean.

DO NOT use water or liquid cleaners.

Springs Window Fashions Limited Warranty

WHAT IS COVERED

This product is warranted against original defects in materials or workmanship for the time period specified below, provided that the product was properly installed, the product was made or assembled exclusively from Springs Window Fashions' materials and components, and all Springs Window Fashions' recommendations were followed with regard to limitations and specifications. This warranty extends only to you as the original purchaser of the product.

Limited Lifetime Warranty

- Cellular shades
- Roller shades
- Solar shades
- Roman shades
- Natural shades
- Pleated shades (with looped tape)
- Sheer shades
- Layered shades
- Wood blinds
- Faux wood blinds*
- Composite blinds
- Wood shutters
- Composite shutters
- Sliding panels
- 1" and 2" aluminum horizontal blinds
- 2" vinyl horizontal blind headrails and components
- Vertical blind headrails, channel panels, and sheer fabric
- Painted and stained valances
- Painted and stained cornices
- Ladders and cloth tapes

*Excludes Foundations faux wood blinds (see Five-Year Warranty)

WHAT IS NOT COVERED

- Unfinished cornices, valances, or Palladian shelves
- Normal wear and tear, including:
 - Loss of color intensity, discoloration, fading, cracking, or yellowing caused by long exposure to direct sunlight
 - Slight color variation
 - Natural variations in color or grain of wood
 - Natural variations, cracking, splitting, twisting, bowing, shrinking, or stretching of organic material used in natural shades
 - Slight warpage of wood blinds or shutters; excessive warpage of wood blinds or shutters caused by moisture or high humidity
- Exterior solar shades damage caused by inclement weather, windy conditions, coastal/salt conditions, pressure washing, or exposure to chemicals including chlorine
- Shutters damage caused by improper maintenance, including sanding, improper washing, and use of razor blades or sealants
- Fabric damage caused by abuse, accidents, alterations, misuse, or failure to follow measuring/installation/use/cleaning/maintenance instructions

WARRANTY OBLIGATIONS

The obligations of Springs Window Fashions are limited to the replacement or repair of parts or products found to be defective. If repairs are made under this warranty, the repairs will be made with like or similar parts. It is at the sole discretion of Springs Window Fashions to determine whether product will be replaced or repaired.

Springs Window Fashions is not responsible for shipping costs or labor costs, for measuring or taking the product down, or for remeasuring or reinstalling the product.

Springs Window Fashions may defer actions on any claim for warping for a period of up to twelve (12) months from the date of the claim in order to permit acclimating to humidity and temperature conditions.

Warranty coverage applies to defective product only. Other window coverings in the room/household will not be replaced.

THIS WARRANTY IS EXCLUSIVE AND IN LIEU OF ALL OTHER WRITTEN OR ORAL WARRANTIES OR OBLIGATIONS AND LIABILITIES. THE DURATION OF ANY IMPLIED WARRANTIES FOR ANY PRODUCT IS LIMITED IN DURATION TO THE WARRANTY TERM APPLICABLE TO SUCH PRODUCT AS SET FORTH ABOVE.

SPRINGS WINDOW FASHIONS SHALL HAVE NO LIABILITY WHATSOEVER FOR INCIDENTAL, PUNITIVE, OR CONSEQUENTIAL DAMAGES.

Some states do not allow the exclusion or limitation of incidental, punitive or consequential damages, so this limitation or exclusion may not apply to you.

No person is authorized to extend or alter this warranty.

Five-Year Warranty

- Foundations faux wood blinds
- Motorized components and accessories (batteries not included)
- Exterior solar shades
- Draperies
- Fabric-covered cornices and valances
- Fabric-tailored shades and accessories

Three-Year Warranty

- Operating cords
- Pleated shades (without looped tape)
- 2" vinyl horizontal blind slats
- Vertical blind vanes

SERVICE

To learn more about warranty claims, contact customer service at 1-800-221-6352 or [windowfashions@springswindowfashions.com](mailto>windowfashions@springswindowfashions.com).

Warranty claims must be accompanied by the original sales receipt, along with details regarding the nature of the problem, location of the product, etc. Warranty claims may be submitted to the Customer

Service Center at:

Customer Service Center
Springs Window Fashions, LLC
8467 Route 405 Highway South
PO Box 500
Montgomery, PA 17752-0500



Bali is a brand of Springs Window Fashions, the Best Experience Company

Bali and the Bali logo are registered trademarks of Springs Window Fashions, LLC.

(5/24) 24-522304