

CLASSIC ROMAN SHADES



MAY 2024

Product Information Guide

Fabric Considerations and Features

Color Variation, Light Control and Privacy, Fabric Features, Oeko-Tex® Standard 100 Certified Fabrics, Swatches2
Features and Benefits of Our Classic Roman Shades.....3
Safety Features of Our Classic Roman Shades.....4
Fabric Styles and Information, Trim Styles.....5

Size Considerations

Lift Options, Continuous-Loop Lift.....6

Options

Classic Roman Shade Styles, Hardware7
Motorized Lift, Multiple Shades on One Headrail8

Measuring

Measuring Guidelines for Shades, Shade Stack Height Chart9
Corner Windows.....10
Bay Windows11

General Information

Bottom Panel Heights.....12
Panel Count Chart: Cordless Lift, Continuous-Loop Lift, and Motorized Lift13

PLEASE NOTE:

Photos and illustrations are for inspiration only.
Not all product configurations are available in all countries.

Window blinds with a damaged or loose tension device or retractable cord that fails to fully retract pose a strangulation risk to children. To avoid this potential strangulation risk, consider purchasing cordless products or products with inaccessible cords.

Fabric Considerations

Color Variation

- Fabric appearance can vary based on lighting and time of day, as well as when the shade is partially or fully lowered
- Color may vary between dye lots; to ensure color consistency, please order shades for the same room at the same time

Light Control and Privacy

- Sheer: semi-transparent fabric, allows light to filter through; images and shapes can be seen through these shades
- Light filtering: allows light to gently filter through and provides some privacy; images and shapes may be seen through these shades, but details are not visible; deep fabric colors provide moderate light control; light colors provide lower light control
- Room darkening: allows some light to filter into the room and provides privacy; objects in a lit room seen through these shades appear as vague shapes; deep fabric colors darken a room; light colors filter and diffuse bright sunlight

Fabric Features

- Shades and valances are one continuous piece of fabric, up to the width of the fabric; this provides a unified, finished appearance
- Applied backing creates a neutral street side appearance

Oeko-Tex® Standard 100 Certified Fabrics

Oeko-Tex Standard 100 certifies that our fabrics are free of PVC, halogen, lead, formaldehyde, allergenic dyes, pesticides, phenols, heavy metals, and meet all VOC content limits.

www.oeko-tex.com

See page 5 to view which fabrics are Oeko-Tex certified



Swatches

- Fabric swatches are available to order at no charge; limit 10 per order; dye lots may vary between swatches and production

Features

Features and Benefits of Our Classic Roman Shades

Finished Edges

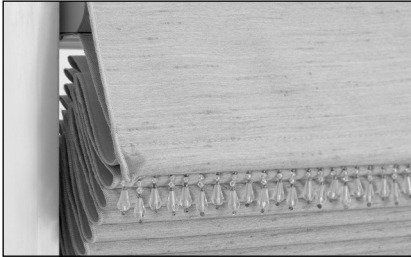

Finished edges guarantee fabric will not fray.

NOTE: Castleweave collection does not have finished edges due to fabric construction.

Shade Components



All shade components, cords, tassels, joiners, and flush mount end caps are color coordinated with the front fabric for a clean, finished look.

Fabric Valance

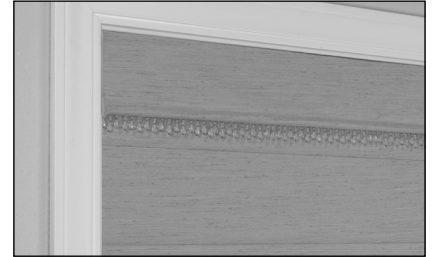

Provides an added decorative touch to the top of the shade, concealing the front of the headrail (returns are not available). Valance is free of charge at time of order. Trim may be added to the bottom of the valance for an additional surcharge.

Multiple Shade Option

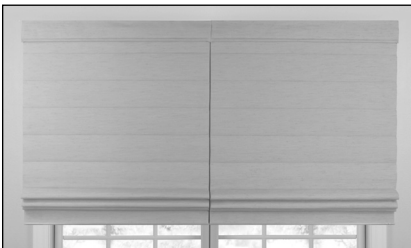

Available two or three-on-one headrail, providing a fabric solution for wider windows. Standard valances will have the same break as the shades. Two-on-one headrail available with continuous-loop lift, and cordless lift controls. Three-on-one headrail available with continuous-loop lift or cordless lift controls.

Bottomrail



Clear sill rail protects the bottom of the shade from dirt and wear.

Panel Height

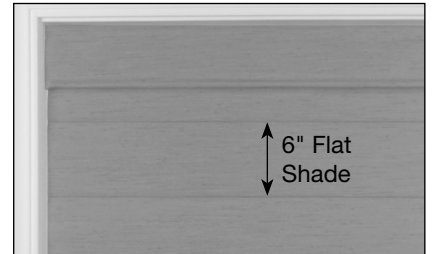

The standard panel height is 6" for flat and 4⁵/₁₆" for looped style. Bottom panel is used as the adjustment panel to get to finished shade height. The bottom panel will vary depending on the shade height.

Aluminum Headrail



Aluminum headrail is color coordinated to the shade fabric, and extremely durable.

Standard control:

- 7/8" x 1 3/4" depth

All other controls:

- 1 1/16" x 2 1/8" depth

Packaging



Mylar tubes are inserted between the Roman panels prior to shipping. This reduces any wrinkling during shipping.

Features

Safety Features of Our Classic Roman Shades

Cordless Lift Option



Provides safety with no external cords on front side. Clean aesthetics. Perfect for homes with children and pets. Shades wider than 48" will have two wands for shade operation.

Motorized Lift Option



Allows easy operation for hard-to-reach or large shades from anywhere in the room. Provides safety for homes with children and pets.

Continuous-Loop Lift Option



White continuous-loop cord helps to lift larger and heavier shades. The lift allows you to stop the shade at any point, holding the bottomrail level. Cord loop guide provides tension and must be installed for shade to operate.

Safety Loop Cord

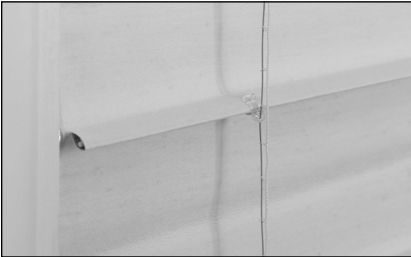

Our safety loop cord construction meets all child safety standards and prevents cords from being easily pulled away from the shade and forming a loop.

Features

Fabric Styles and Information

Fabric Styles	Fabric Width (inches)	Light Control	Privacy	Fabric Content	Oeko-Tex Certified
Castleweave	72	Light Filtering	Moderate	100% polyester with polyester backing	●
Crochet	72	Light Filtering	Moderate	100% polyester with polyester backing	●
Damask	72	Light Filtering	Moderate	100% polyester with polyester backing	●
Dunes	72	Light Filtering	Moderate	100% polyester with polyester backing	●
Fenton	72	Light Filtering	Moderate	100% polyester with polyester backing	●
Fiddlestix	72	Light Filtering	Moderate	100% polyester with polyester backing	●
Hoehne	72	Light Filtering	Moderate	100% polyester with polyester backing	●
Hoehne II	72	Room Darkening	Complete	100% polyester with blackout backing	●
Hysham	76	Sheer	Minimal	100% polyester	●
Kingfisher	72	Light Filtering	Moderate	93% polyester / 4% cotton / 3% flax with polyester backing	●
Leafmark	72	Light Filtering	Moderate	100% polyester with polyester backing	●
Linen	72	Light Filtering	Moderate	88% polyester / 7% cotton / 5% flax with polyester backing	●
Mudbloom	70	Light Filtering	Moderate	100% polyester with polyester backing	●
Paragon	70	Light Filtering	Moderate	100% polyester with polyester backing	●
Rockaway	72	Light Filtering	Moderate	93% polyester / 4% cotton / 3% flax with polyester backing	●
Stonefield	72	Light Filtering	Moderate	100% polyester with polyester backing	●
Terrace	72	Room Darkening	Complete	100% polyester with blackout backing	●
Tungsten	72	Light Filtering	Moderate	100% polyester with polyester backing	●
Velour	72	Light Filtering	Moderate	100% polyester with polyester backing	●
Waterfront	72	Light Filtering	Moderate	100% polyester with polyester backing	●

Trim Styles

- For surcharge, see price charts
- Optional trims are attached to the bottom edge of the valances only

1" Teardrop Crystal Bead Trim



1" Teardrop Crystal Bead Trim

Bronze	201	White	205
Sand	204		

7/16" Gimp Trim





7/16" Gimp Trim

Cream	715	Toffee	296
Dark Beige	350	Tender Taupe	103
Morning Glory	639	White	417
Rock Gray	399		

Size Considerations

Lift Options

									
	Width		Height		Width		Height		
	Min* (inches)	Max (inches)	Min* (inches)	Max (inches)	Min Panel* (inches)	Max Panel	Max Shade (inches)	Min Shade (inches)	Max Shade (inches)
	Cordless Lift Shades	18	See fabric width	18	86	18***	See fabric width	144	18
Continuous-Loop Lift Shades	18	See fabric width	18	96	18***	See fabric width	120	18	96

70" wide fabric: Mudbloom, Paragon

72" wide fabric: Castleweave, Crochet, Damask, Dunes, Fenton, Fiddlestix, Hoehne, Hoehne II, Kingfisher, Leafmark, Linen, Rockaway, Stonefield, Terrace, Tungsten, Velour and Waterfront



76" wide fabric: Hysham

*For all inside mount applications, $\frac{3}{8}$ " deduction is taken by manufacturer on overall width.

**Available in two-on-one headrail only.

***Available in two-on-one or three-on-one headrail.

Depth Requirements for Inside Mount

Lift Option and Shade Style	Headrail Dimensions (inches)		
		Minimum Depth Mount (inches)	Flush with Casing (inches)
Cordless Lift and Continuous-Loop Lift: Flat	1 $\frac{1}{16}$ x 2 $\frac{1}{8}$	$\frac{5}{8}$	2 $\frac{3}{8}$
Cordless Lift and Continuous-Loop Lift: Looped	1 $\frac{1}{16}$ x 2 $\frac{1}{8}$	$\frac{5}{8}$ (fabric loops will overhang approximately 3" into the room)	2 $\frac{3}{8}$ (fabric loops will overhang approximately 3" into the room)

Continuous-Loop Lift

Control length for continuous-loop lift shades varies based on the finished shade height (see right). Optional cord loop length (sizes listed below chart) available upon request.





Finished Shade Height (inches)	Cord Loop Length (inches)
12 to 26	18
26 $\frac{1}{16}$ to 38	24
38 $\frac{1}{16}$ to 50	36
50 $\frac{1}{16}$ to 62	48
62 $\frac{1}{16}$ to 74	60
74 $\frac{1}{16}$ to 96	72

Optional cord lengths: 84", 96", and 108".

Options

Classic Roman Shade Styles

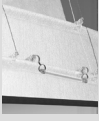
Option surcharges may apply. See price charts for details.

		Control Choices			Shade Options				Finishing Options			Info	
		Cordless Lift	Motorized Lift	Continuous-Loop Lift	Valance: Length 5¼"	Corner Window	Bay Window	Multiple Shades: Two-on-one Headrail	Multiple Shades: Three-on-one Headrail	Brackets: Extension, Hold Down*, Side Mount*	Valance Trim	Wood Cornice	Coordinating Cords
Looped Roman Shade: 4½" Looped Pleat		•	•	•	•	•	•	•	•	•	•	•	•
Classic Flat Roman Shade: 6" Flat Panels		•	•	•	•	•	•	•	•	•	•	•	•
Cordless Lift**		•			•	•	•	•	•	•	•	•	•
Motorized Lift			•		•	•	•			•	*	•	
Continuous-Loop Lift				•	•	•	•	•	•	•	•	•	•

*Not available with motorized lift control option.

**Vertical wand used with bottom panels greater than 2¾". Horizontal wand used with bottom panels less than 2¾".

Hardware

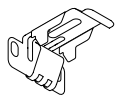

Installation Brackets

Cord lift: hidden snap-in design for easy installation

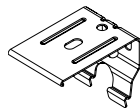

Cordless, motorized, and continuous-loop lift: hidden snap-in design for easy installation

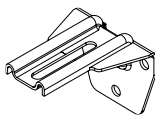

Short: adds up to 1" extension from the wall

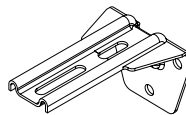

Extension Brackets

Medium: adds up to 1½" extension from the wall

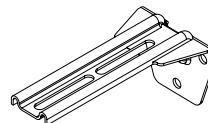

Long: adds up to 2½" extension from the wall

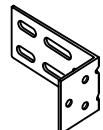

Side Mount Brackets

Maximum width 60"

Options

Motorized Lift

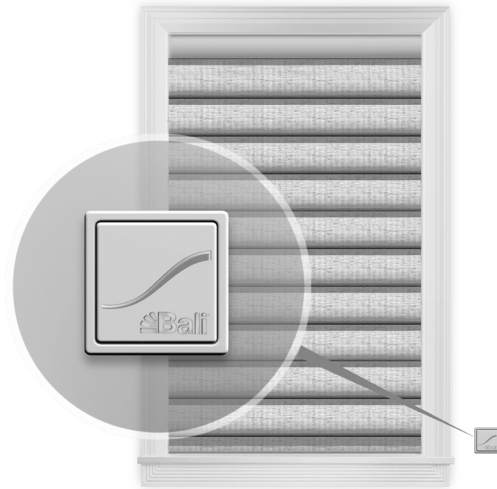

- Refer to motorization product information guide for additional options, sizing, and pricing
- Window treatments can be operated from virtually anywhere in the home
- Provides easy operation of hard-to-reach or large windows
- Efficiently manages energy (heat gain and loss)
- Operate multiple window treatments simultaneously or individually
- A safer alternative to accessible cords that are traditionally used to operate window coverings; ideal for homes with children and pets
- Easily integrated with home automation systems
- Low voltage motorization requires no costly electrical hard-wiring
- Multiple control and power options available

NOTE: Motorization components and accessories have a five-year limited warranty, excluding batteries.

Multiple Shades on One Headrail

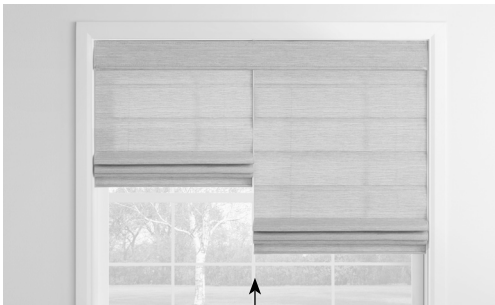

1/4" spacing

- For surcharge, see price charts
- Available as two or three-on-one headrail
- See chart below for available lift options
- Available in flat and looped styles
- Standard valances on multiple shades will have the same breaks as the panels
- Continuous valance covering multiple shades is not available

	Maximum Overall Size for Multiple Shades* (inches)	Maximum Width with Side Mount (inches)	Control Locations	Gap (inches)
Continuous-Loop Lift: Single Control	120 x 96	60	Two-on-one: common lift cord can be on right or left to operate both shades at the same time Three-on-one: common lift cord can be on right or left to operate all shades at the same time	1/4
Continuous-Loop Lift: Multiple Control	144 x 96	60	Two-on-one: left shade, left control; right shade, right control Three-on-one: left shade, left control; right shade, right control; middle shade, common right or left; continuous-loop lift cannot be used in the middle of the headrail on multiple shades	1/4
Cordless Lift	144 x 86	60	Not applicable	1/4

*See size considerations or individual descriptions in the options section for maximum panel widths and heights.

Measuring

Measuring Guidelines for Shades

Measuring for an Inside Mount

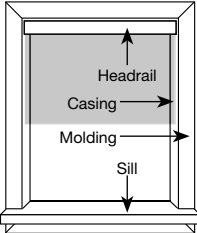
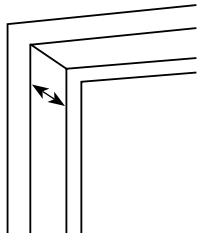
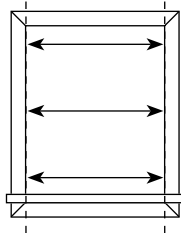
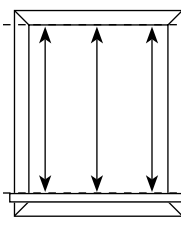
<p>Inside Mount: Window treatments are installed inside the window casing.</p> <p>Use a steel tape measure for taking measurements.</p> 	<p>1. Measure Depth: See chart below to determine if window casing has enough depth for an inside mount window treatment.</p> 	<p>2. Measure Width: Measure the inside width of window casing in three places; record narrowest measurement.</p> 	<p>3. Measure Length: Measure the inside length from the top of window casing to the top of the sill in three places; record longest measurement.</p> 
--	--	---	--

NOTE: Do not take any deductions for clearance. The manufacturer will take necessary deductions for a perfect fit.

Measuring for an Outside Mount

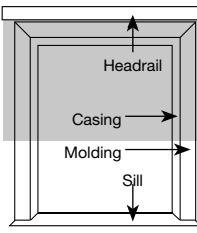
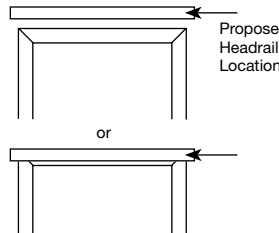
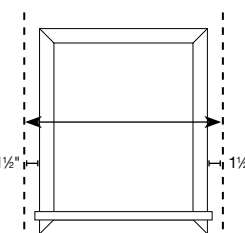
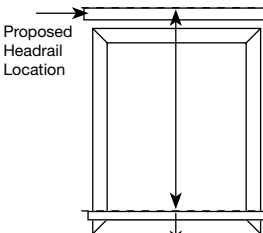
<p>Outside Mount: Window treatments are installed outside the window casing.</p> <p>Use a steel tape measure for taking measurements.</p> 	<p>1. Determine Headrail Location: Determine if headrail will be on molding or above molding and mark the spot.</p> 	<p>2. Measure Width: Measure exact width to be covered; we recommend 1/2" overlap on each side of the window (3" total) for optimal light control and privacy; record measurement.</p> 	<p>3. Measure Length: Measure exact length to be covered, including desired overlap (typically from 1" above the molding to bottom of sill or apron); record measurement.</p> 
--	--	--	--

NOTE: The manufacturer makes no deductions on outside mount installations.

Shade Stack Height Chart

Looped

Finished Shade Height (inches)	Stack Height (inches)
Up to 29	9
29 to 41	10
41 to 58	11
58 to 75	12
75 to 96	13

Flat

Finished Shade Height (inches)	Stack Height (inches)
Up to 32	10
32 to 56	11
56 to 80	12
80 to 96	13

NOTE: Stack height includes headrail and sill rail.

This chart is an approximation of the largest stack possible for all control types at each height range.

Measuring

Corner Windows

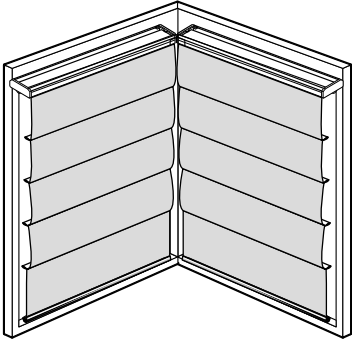

Shades on Corner Windows

- **No charge**
- Made as individual shades
- Each shade will have its own control; we recommend opposite corners
- Indicate left or right for each shade
- Manufacturer will take appropriate deductions for proper fit; DO NOT order as a corner shade if you do not want manufacturer to take deductions
- Flat style is recommended for corner windows
- Looped style will have light gaps due to fabric loops

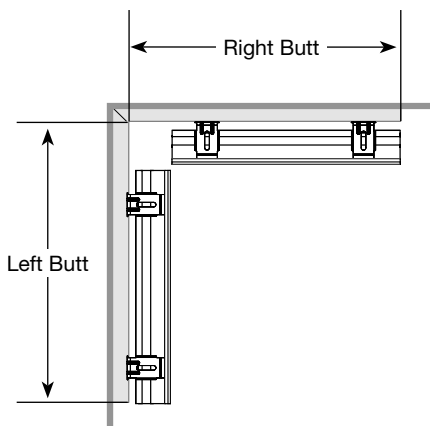

Measuring Information

Mounting on a Wall or Molding:

Measure the width of each window from the corner on the mounting surface (molding or wall) to the point you would like to cover.

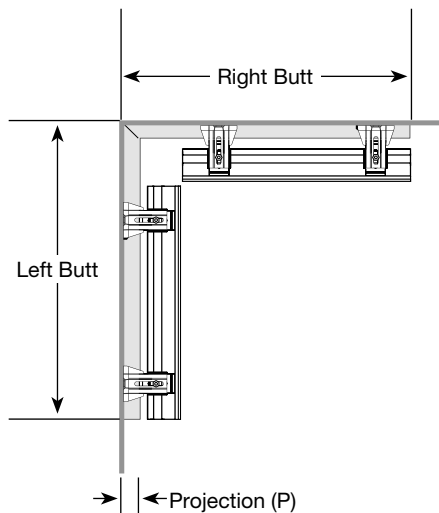

Mounting Above the Molding:

Measure the width of each window from the corner on the mounting surface to the point you would like to cover.

Projection measurement is the distance needed to clear any molding or obstructions that the shade will be mounted above.

NOTE: The projection (P) distance is needed to correctly calculate deductions for installations where the shades will use shims or projection brackets to clear molding. All projection distances must match for correct deductions to be calculated.

Measuring

Bay Windows

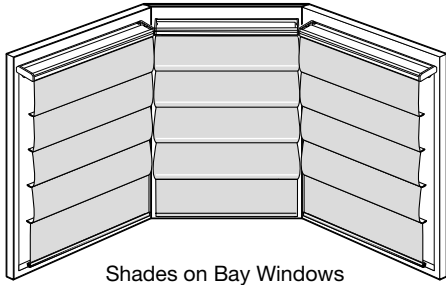

Shades on Bay Windows

- **No charge**
- Made as individual shades
- Each section will have its own control
- Manufacturer will take appropriate deductions for proper fit; **DO NOT** order as a corner shade if you do not want manufacturer to take deductions
- Flat style is recommended for bay windows
- Looped style will have light gaps due to fabric loops

Measuring Information: Three-Sided Bay Window

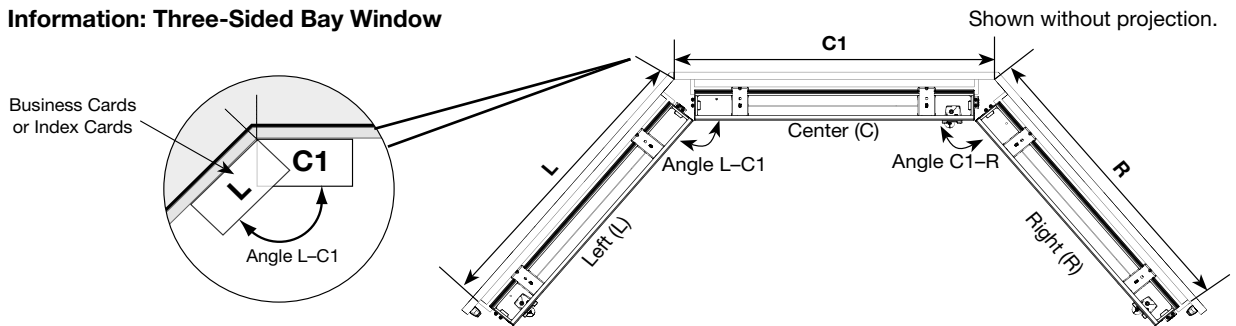

Measure:

L and R: Width of each side window from the corners on the mounting surface to the point you would like to cover.

C1: Width of the center window on the mounting surface from corner to corner.

Angle L-C1: Angle between the (L) and (C1) windows.
Angle C1-R: Angle between the (C1) and (R) windows.
Projection: If needed: The depth of the trim or molding the shade will be mounted above.

Measuring Information: Four-Sided Bay Window

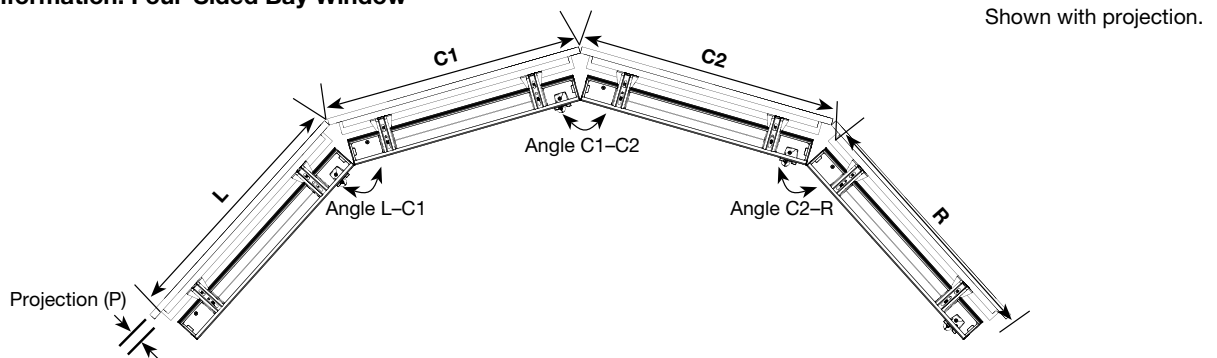

Measure:

L and R: Width of each side window from the corners on the mounting surface to the point you would like to cover.

C1, C2: Width of each center window on the mounting surface from corner to corner.

Angle L-C1: Angle between the (L) and (C1) windows.
Angle C1-C2: Angle between the (C1) and (C2) windows.
Angle C2-R: Angle between the (C2) and (R) windows.
Projection: If needed: The depth of the trim or molding the shade will be mounted above.

NOTE: The projection (P) distance is needed to correctly calculate deductions for installations where the shades will use shims or projection brackets to clear trim or molding. All projection distances must match for correct deductions to be calculated. For additional windows on bays with up to five sides continue with number progression for center shade sizes (C1, C2, C3, ...) and angles (angle C1-C2, angle C2-C3, ...) as needed. Measure each bay angle using a protractor or angle finder or use two business cards in each bay corner as illustrated above and fax to customer service 1-800-552-4559.

The angle to use between adjacent center bay windows along a straight section of wall is 180 degrees.

General Information

Bottom Panel Heights

The standard panel height is 6" for flat and 4⁵/₁₆" for looped style. Bottom panel is used as the adjustment panel to get to finished shade height. The bottom panel height varies depending on shade height. A small change in finished shade height can create significantly different looks.

For example:

Finished Shade Height* (inches)	Flat		Looped	
	Number of Full Panels	Approx. Bottom Panel Height (inches)	Number of Full Panels	Approx. Bottom Panel Height (inches)
60	9	5 ³ / ₈	13	3 ³ / ₈
61	10	3 ¹ / ₈	14	0
61	10	3 ¹ / ₈	14	0
62	10	1 ³ / ₈	14	1

*Approximate

IMPORTANT ORDERING NOTE:

For shades hanging in the same room at the same height or for groups of shades, please add the words "hanging side-by-side" to the order comments. This is important for the manufacturing process and for panel adjustments.

NOTE: It is very important to consider this possible variation when ordering more than one shade for a room. For approximate panel counts see the following pages.

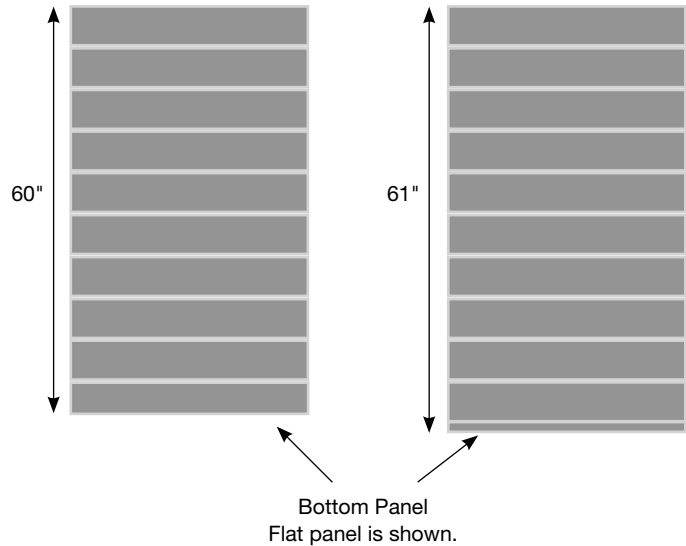

General Information

Panel Count Chart: Cordless Lift, Continuous-Loop Lift, and Motorized Lift

The purpose of this information is to help the consumer visualize what their shade will look like by approximating the number of full panels and the bottom panel length. Full panel lengths are 6" for flat and 4⁵/₁₆" for looped; however, the bottom panel is used as the adjustment panel to get to finished shade height. **Therefore, the bottom panel length varies depending on shade height.** A small change in finished shade height can create significantly different looks.

This chart should be used to compare the effect of various lengths. The information can vary depending on the pleat length tolerance.

Finished Shade Height* (inches)	Flat		Looped	
	Number of Full Panels	Approx. Bottom Panel Height (inches)	Number of Full Panels	Approx. Bottom Panel Height (inches)
18	2	4½	3	3⅝
19	2	5½	4	¼
20	3	½	4	1¼
21	3	1½	4	2¼
22	3	2½	4	3¼
23	3	3½	4	4¼
24	3	4½	5	1
25	3	5½	5	2
26	4	½	5	3
27	4	1½	5	4
28	4	2½	6	⅝
29	4	3½	6	1⅞
30	4	4½	6	2⅝
31	4	5½	6	3⅝
32	5	½	7	⅜
33	5	1½	7	1⅞
34	5	2½	7	2⅞
35	5	3½	7	3⅞
36	5	4½	8	0
37	5	5½	8	1
38	6	½	8	2
39	6	1½	8	3
40	6	2½	8	4
41	6	3½	9	⅜
42	6	4½	9	1¼
43	6	5½	9	2¼
44	7	½	9	3¼
45	7	1½	10	⅜
46	7	2½	10	1⅞
47	7	3½	10	2⅞
48	7	4½	10	3⅞
49	7	5½	11	⅞
50	8	½	11	1⅞
51	8	1½	11	2⅞
52	8	2½	11	3⅞
53	8	3½	11	4⅞
54	8	4½	12	⅜
55	8	5½	12	1¼
56	9	½	12	2¼
57	9	1½	12	3¼

Finished Shade Height* (inches)	Flat		Looped	
	Number of Full Panels	Approx. Bottom Panel Height (inches)	Number of Full Panels	Approx. Bottom Panel Height (inches)
58	9	2½	13	½
59	9	3½	13	1½
60	9	4½	13	2½
61	9	5½	13	3½
62	10	½	14	⅞
63	10	1½	14	1⅞
64	10	2½	14	2⅞
65	10	3½	14	3⅞
66	10	4½	14	4⅞
67	10	5½	15	⅞
68	11	½	15	1⅞
69	11	1½	15	2⅞
70	11	2½	15	3⅞
71	11	3½	16	½
72	11	4½	16	1½
73	11	5½	16	2½
74	12	½	16	3½
75	12	1½	17	¼
76	12	2½	17	1¼
77	12	3½	17	2¼
78	12	4½	17	3¼
79	12	5½	17	4¼
80	13	½	18	⅞
81	13	1½	18	1⅞
82	13	2½	18	2⅞
83	13	3½	18	3⅞
84	13	4½	19	⅞
85	13	5½	19	1⅞
86	14	½	19	2⅞
87	14	1½	19	3⅞
88	14	2½	20	¼
89	14	3½	20	1¼
90	14	4½	20	2¼
91	14	5½	20	3¼
92	15	½	20	4¼
93	15	1½	21	1
94	15	2½	21	2
95	15	3½	21	3
96	15	4½	21	4

*Finished shade height equals ordered height; there are no factory deductions for height.

EXAMPLE: A flat shade with a 48" finished shade height will have seven full panels and the eighth panel will be approximately 5⅞" long.



Bali is a brand of Springs Window Fashions, the Best Experience Company

Bali and the Bali logo are registered trademarks of Springs Window Fashions, LLC.

(5/24) 24-523154