



natural shades



PRICE LIST AND PRODUCT INFORMATION GUIDE FOR **NATURAL** SHADES

April 2010

The name Bali® has been synonymous with window treatments for nearly four decades. Today, Bali proudly holds a leadership position among all product offerings within the window fashions industry. It captures the essence of today's decor trends and provides style, selection and function at an affordable price.

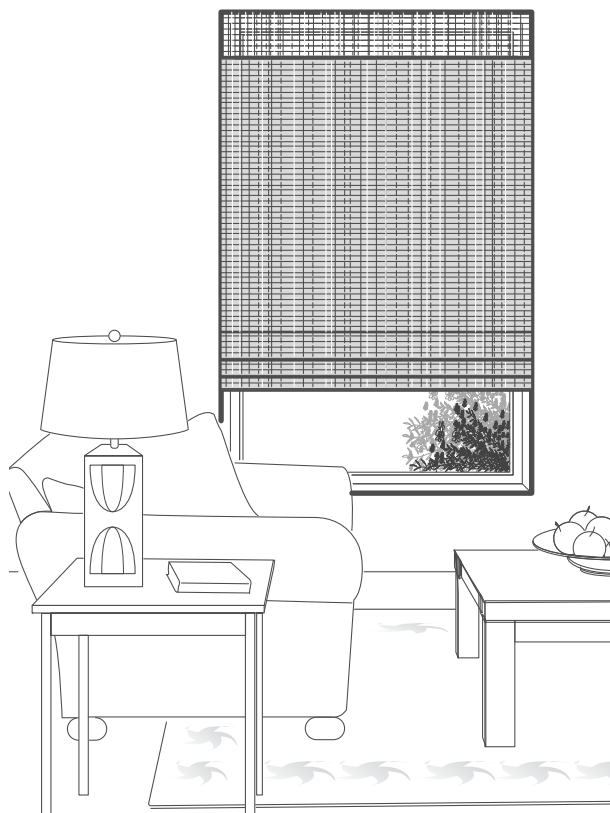

Bali Natural Shades are crafted from bamboo reed, bamboo slat, sisal and grass cloth, jute and straw materials. They add natural color, texture and dimension to your windows and create a comfortable atmosphere of casual elegance or simple sophistication.

Features

- Standard Roman or Looped Roman Shade Design
- Wide Selection of Colors, Textures and Unique Weaves
- Standard Cord Control
- Motorization
- Natural Drape for Large Windows and Patio Window Solutions
- Hardwood Headrail

Options

- Continuous-loop Lift Control
- Valances: Standard 6" or 9", Deco-Trim with Fringe, or 3½" Traditional Wood
- Wood Cornices
- Hems: Deco-Trim with Fringe or Deco-Pocket with Accent Rod
- Wood Hem Bar
- Decorative Edge Banding
- Privacy and Room-darkening Liners
- Multiple Shades on One Headrail
- Bottom Up/Top Down
- Angle Top Shades
- Cut-Outs
- Mitered Corners
- Valance Only Shades

Characteristics of Natural Shade Materials

Nature's Beauty

There simply is no substitute for the beauty of the materials used in Natural Shades. The colors and textures of bamboo, reeds, grass, jute and rattan have a distinct character and one-of-a-kind look that synthetic materials can't match.

However, with character come inherent natural properties that may influence the appearance of the finished shade. Recognizing and understanding the characteristic traits of natural materials will provide more satisfaction and enjoyment by knowing why each shade is truly unique!

Characteristics

Asymmetry

Materials used in Natural Shades are grown and harvested naturally. Variations in shape, thickness, texture and graining are to be expected from Mother Nature. While providing personality to each shade, these variations create asymmetry in the weave that may alter the appearance of the finished shade. Specifically, you may notice:

- **Uneven spacing or gaps** – differences in bamboo or reed shapes and thicknesses can create uneven spacing or gaps in the weave
- **Pattern changes or gaps** – different thicknesses of grassy materials, tied knots and splices can create visual disruptions in the weave pattern or gaps in the weave
- **Length differences** – variations in bamboo thicknesses, bamboo joints or reed sizes can create length differences from one side of the shade to the other
- **Bowing or arching** – different drying rates of bamboo fibers on one side and skin on the other side of the bamboo slat can create a bowing or arching effect in the finished shade.

All materials used are hand-selected to strict specifications to minimize variations. These variations are not considered flaws, but rather are normal characteristics to be expected from natural-grown materials.

Color

Mellowing with age, bamboo, reeds, jute, grasses and other natural materials will change slightly in color over time. Depending on material composition, they may lighten or darken due to direct sunlight or other climatic conditions. Uncolored bamboo will experience the most color shift, changing from a green color at harvest to a yellow-brown color over three to six months. Color matches from shade to shade cannot be guaranteed as these are natural reactions to aging.

Stretching

The natural elasticity of yarns combined with the weight of the woven material may cause shades to stretch upwards of 1" to 1½" after installation. This is particularly noticeable on inside mount shades or shades that extend from ceiling to floor. Ordering the shade shorter than needed will help compensate for stretching over time. Note that the addition of edge banding will not only add a truly personal and decorative touch, but will also help to control the stretching.

Every material used in Natural Shades comes with its own one-of-a-kind personality. By understanding these inherent traits of natural material, we hope that you will appreciate each unique characteristic and will enjoy your shades for many years to come!

How to Place an Order: Natural Shades

The following must be specified to place your order:

1. QUANTITY of shades

2. SIZE OF SHADES: **width** first, then **height**.

See page 7 for "How to Measure" Instructions.

3. INSIDE OR OUTSIDE MOUNT:

For inside window frame installation, mark order "Inside Mount".

For outside window frame installation, mark order "Outside Mount".

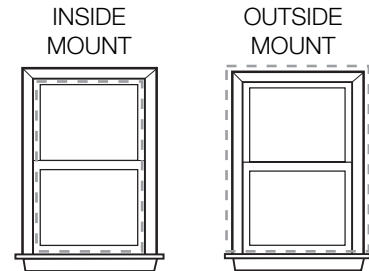

4. CONTROL OPTIONS:

- Standard Cord Control: Color-coordinated cords with wood tassels for raising and lowering shades (see pages 39-40 for more details).
 - Continuous-loop Lift Control: Raises and lowers larger shades smoothly and effortlessly, features safety cord tensioner (see page 41 for more details).
 - Motorization: Used when ease of operation is important or in hard to reach places
-

5. CONTROL LOCATION:

Controls on right or left side of shade.

6. SHADE MATERIAL

When placing your order, specify:

- Fabric name
 - Color name
 - Color number
-

7. SHADE STYLE OPTIONS:

- Standard Roman Style (see page 39 for more details)
 - Looped Roman Style (see page 40 for more details)
-

8. VALANCE AND HEM SELECTION (SEE PAGE 31-32)

When placing your order, specify:

- Valance name/color and hem name
 - Accent gimp name & color number (required on Deco-Trim Valances, Deco-Trim Hems, Deco-Pocket Hems and Angle Top Shades)
-

9. OPTIONS

The following options are available (see price grid for surcharges and more details):

- | | |
|-----------------------------------|---------------------------------------|
| • Privacy Liner | • Mitered Corner Shades |
| • Room-darkening Liner | • Cut-outs |
| • Fabric Edge Banding | • Bottom Up/Top Down |
| • Valance Only | • Angle Top |
| • Projection Brackets | • Hold-down Brackets |
| • Multiple Shades on One Headrail | • Hem Options (N/A with Edge Banding) |
-

10. DELIVERY: INDICATE "SOLD TO" AND "SHIP TO" ADDRESS(ES).

TO PRICE YOUR ORDER:

1. Select shade type, size, color and options.
 2. Add together the base price for the shade and options to determine total price of the shade.
-

How to Place an Order: Natural Drapes

How to Place an Order

The following must be specified to place your order:

1. Quantity of Blinds

2. Size of Blinds: WIDTH first, then HEIGHT.

See page 7 for "How to Measure" instructions

3. Inside or Outside Mount

For inside window frame installation, mark order "Inside Mount". For outside window frame installation, mark order "Outside Mount".

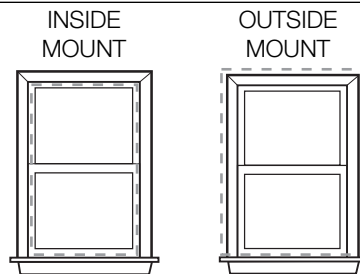

4. Stack

Indicate whether the shade should stack left or right, or split stack.

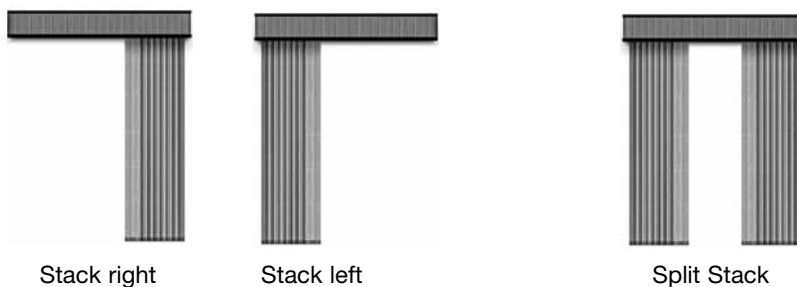

5a. Control Options: Standard Cord Control or optional Wand Control

5b. Control Locations:

For cord control only, indicate whether cord should be located on the left or right side of the shade (right is standard).

NOTE: When the cord location is opposite of the stack location, the cord control will be exposed. The lead side of the Natural Drape will be 3" short of the end of the headrail, which exposes the cord. If cord and stack are on the same side, cord will not be exposed.

Wand control has wand on lead edge of drape(s).

6. Shade Style: When placing your order, specify:

- Fabric Name (style, color and color number)
- Drape Edge Banding (color name and number)

7. Fullness:

- Standard fullness or 60% fullness (see page 30 for illustrations)

8. Valance:

- Self valance with vertical material orientation is standard (all valances have 1" edge banding).
- No valance is optional

9. Delivery: Indicate "sold to" and "ship to" address(es).

TO PRICE YOUR ORDER:

1. Select shade type, size, color and options.
2. Add together the base price for the shade and options to determine total price of the shade.

Shade and Drape Liners and Edge Banding Options and Natural Drape Information

Shade and Drape Liners

- Liners are an 80/20 poly/cotton blend, and are available up to 96" wide on shades; available up to 192" on drapes.

**Privacy Liner colors available
(same color front and back):**

- Buff 0093
- Chestnut 0297
- Espresso 0632
- Soft White 0417

**Room-darkening Liner colors available
(neutral to street, color to material side)*:**

- Buff 5093
- Chestnut 5297
- Espresso 5632

* Liner reversal available.

See page 44 for suggested liner color coordination.

Shade Fabric Edge Banding

- 1" and 2" fabric banding frames the shade
- Fabric Edge Banding is not available on Arima, Grasses, Margarita or Nassau styles
- Fabric Edge Banding not available on Deco-Trim or Deco-Pocket hems, Angle Top Shades, Cut-Outs, or with hold-down brackets
- Deco-Trim valance may be ordered with Fabric Edge Banded shade, but this valance will not have Fabric Edge Banding on the outside edges
- **Surcharge: Standard Roman – \$58
Looped Roman – \$71**

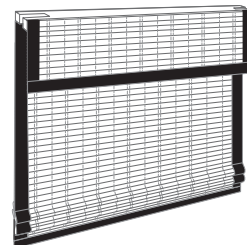

Natural Drape

- Natural Drape features the soft rolling qualities of drapery in vertically oriented Natural Shade material
- Features corded control in single or split stack. Optional wand control available at no charge.
- Choose from standard fullness (1%), when closed, waves slightly or a 60% fullness, when closed, features drapery-like appearance.
- Valance with vertically oriented material and a liner is included at no charge, or order shade without valance (not recommended) optional at no charge
- Valance and returns will extend 1/2" further than drape width.
- Edge Banding is required on the drape and valance. Select from 1" or 2" Edge Banding for the drape. Valance uses matching 1" Edge Banding.
- See price pages for more product detail.

Natural Drape Edge Banding

- Select 1" and 2" colors available on top and bottom of drape: **No charge**
- Optional 1" and 2" colors available on drape sides: **No charge**
- 1" Edge banding of same color will be on top and bottom edge of valance

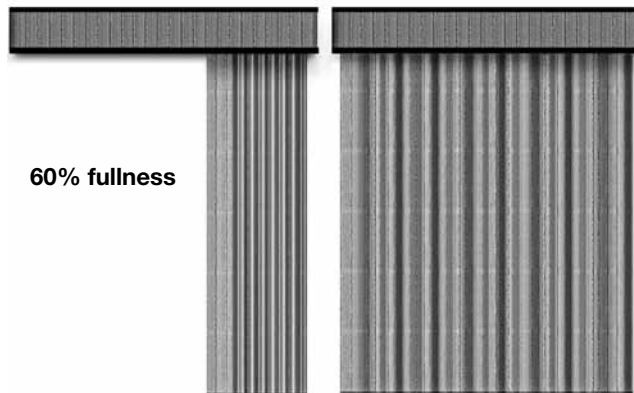
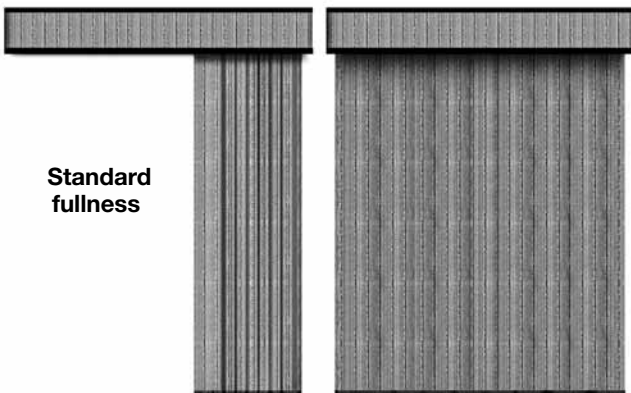

NOTE: Not available with Arima, Grasses, Legends, Maracaibo, Margarita, Nassau, Retreat or Valera.

Natural Shade Valance and Hem Options

6" Standard Valance (Optional 9" Valance)

- Standard cord controls
 - 6" valance standard
 - 9" valance is optional; **surcharge \$5**
- Continuous cord loop
 - 9" valance standard (6" valance is not available)
- Liner available on 6" and 9" valances (not available on Deco-Trim Hem)
- Edge banding will be applied to the sides and bottom of the valance if option is chosen for complete shade; see page 30
- Valance returns are standard on outside mount shades; available upon request on inside mount shades
- No special valance return lengths available
- Special valance return widths of 1½" to 3½" are available upon request

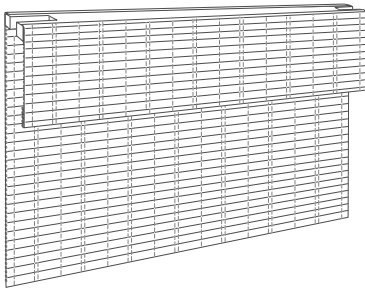

Wood Hem Bar

- See price grids for surcharge
- Decorative wood hembar adds a finishing touch
- 5 popular finishes that coordinate with the Wood Cornices

Colors Available:

Deep Cherry	1316
Maple.....	1039
Natural.....	1036
Snowflake.....	1603
White Cotton	1424

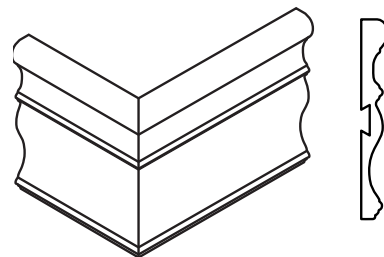
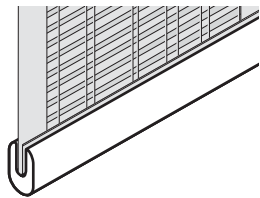

Traditional Wood Valance

See price grids for surcharge

- Features a 3½" decorative wood valance that resembles crown molding
- Shade Edge Banding and liners available with Traditional wood valance option – add appropriate surcharges
- Valance returns of ½" to 4⅞" are available for inside mount shades
- Valance returns are standard on outside mount
- Shades ordered as OUTSIDE MOUNT will be supplied with returns sized to cover the end of the shade back to the mounting surface; if projection brackets are requested when the shade is ordered, longer returns will be sent automatically; outside mount shades are available without returns upon request
- Not available with Continuous Loop Controls or Motorized Lift
- Also available on Bali Wood Blinds for a coordinated look throughout your home, see the Bali Woods Sample Book for actual color samples

Colors available:

Deep Cherry	1316
Ebony	1690
Majestic Walnut.....	1041
Natural.....	1036
Regal Oak.....	1038
White Cotton	1424

Valance Only

A separate valance can be ordered for use alone or to complement other window treatments. Valances over maximum material width will be spliced. See appropriate price grid for material width.

The valance material comes attached to a headrail and includes mounting brackets (standard, ceiling, or projection brackets). Fabric edge banding is available with surcharge of \$16.

Width →	18"	24"	31"	36"	42"	48"	60"	72"	84"	96"	108"	120"	144"
6" Standard Valance	\$28	32	39	44	50	57	69	82	95	107	120	132	145
9" Standard Valance	33	37	44	49	56	62	75	87	100	112	125	138	150
Traditional Wood Valance	44	48	58	65	74	83	100	117	133	150	167	184	201
Deco-Trim Valance	44	48	58	65	74	83	100	117	133	150	167	184	201

Natural Shade Valance and Hem Options

Deco-Trim Valance or Hems

Distinctive Valance and Hem designs with accent Gimp.

See price grids for surcharge

SEASCAPE: Valance

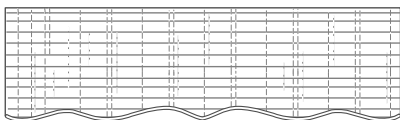

This design is scaled to the width of the shade.

DENTIL: Valance

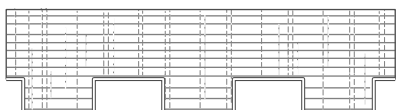

This design will repeat with the width of the shade.

CATHEDRAL: Valance

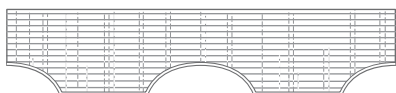

This design will repeat with the width of the shade.

HORIZON: Valance

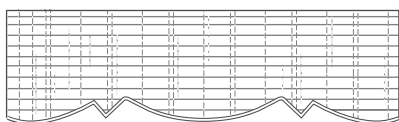

This design is scaled to the width of the shade.

NOTE: Deco-Trim valance or hem designs are cut into the valance or hem of the shade to a depth of approximately 2½". Hems allow light through at the bottom of the shade; if complete privacy and light filtering are desired, add 2½" to the ordered height.

Must select accent gimp with Deco Valance or Hem.

Accent Gimp



Black..... 156	Dark Beige..... 350
Brown 554	Maroon 360
Chocolate 04	Toffee..... 296
Cream..... 715	

Deco-Pocket Hem

See price grids for surcharge

- Distinctive hem designs with decorative accent rod and accent gimp
- 5/8" diameter metal rods with a classic ball finial, cut to width
- Deco-Pocket hems also available without accent rod to add your own decorative hardware
- Not available with cut-out

DENTIL – Hem with Accent Rod

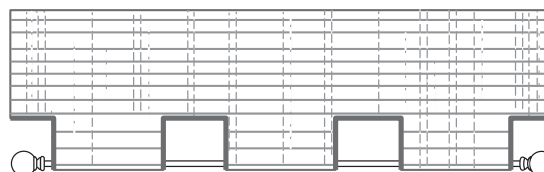

CATHEDRAL – Hem with Accent Rod

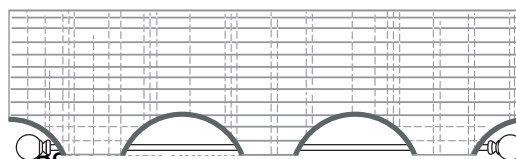

Antique Brass.....	06
Espresso.....	84
Satin Nickel	59

NOTE: Deco-Pocket hem designs are cut into the hem of the shade to a depth of approximately 4½", allowing light through the bottom of the shade. If complete privacy and light filtering are desired, add 4½" to the ordered height

Must select accent gimp with Deco Valance or Hem.

SIZE CONSIDERATIONS FOR ALL VALANCE AND HEM OPTIONS

Minimum width:

- Standard Roman: 10" exact
- Looped Roman: 12" exact
- Bottom Up/Top Down: 14" exact
- Continuous Loop: 24" exact

Maximum width: Single Shade: Deco Trim Valance or Hem: 96"
 Deco-Pocket Hem with Rod: 72" exact
 Multiple Shades on one Headrail: 144" exact

Minimum Height: 10" Standard Roman
 16" Looped Roman

Maximum Height: Standard Cord Control: 120"
 Continuous Loop Control: 108"

Specialty Options

Multiple Shades on One Headrail

1. Measure overall width of area to be covered.
2. Measure width of the area each shade is to cover; measure and specify left shade first, continuing to the right; factory will allow a minimum of $\frac{1}{2}$ " between shades for operating clearance.
3. Total width of all shades, plus clearances, must equal the overall headrail width.
4. To measure height, use standard inside or outside measuring directions (see page 5).
5. For patio doors, measure height to within 1" of the floor either from the ceiling or a point high enough above door to provide clearance; cords should be on outside edges of shades; outside mount (wall) installation is recommended for patio doors.

NOTES:

- Each shade operates separately
- Shade controls can be on the right or left at no charge
 - Standard for two on one headrail: Left panel, left control and right panel, right control
 - Standard for three on one headrail: Left panel, left control; middle panel, right control; and right panel, right control
- Horizontal slat alignment between shades is not guaranteed
- Liner options available
- Fabric edge banding is available and will be attached around each panel
- Shades up to the maximum material width will have a continuous valance (see appropriate price grids); shades over maximum material width will have a valance with each panel
- **Surcharge: \$30**

Three on One Headrail

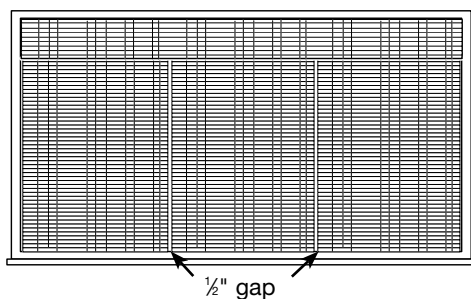

Two on One Headrail

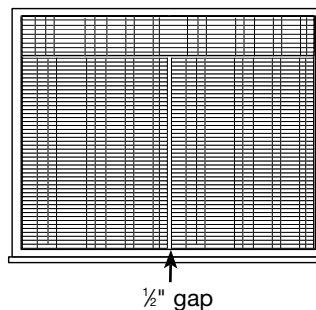

Mitered Bay and Corner Windows (Not available with Natural Drape)

- Mitered corner shades are used to butt two or three shades together in a corner or bay window
- Mitered corner shades cannot be raised to the same height
- Horizontal slat alignment between shades cannot be guaranteed
- Pull cords can be on the right or left side of each shade; locating cords opposite of the miter is recommended
- Mitered shades with more than three sections require a template
- Headrails are mitered for proper fit, measurements must be exact
- Hold-down brackets not available with mitered corner shades
- Bottom Up/Top Down not available with mitered corner shades
- Continuous loop control not available with mitered corner shades
- Looped Roman not available with mitered corner shades
- See next page for ordering details

Natural Shades: Standard Roman Style

Hardwood Headrail
Made from sustainable hardwood resources

6" Valance (standard)

Standard Installation Brackets (steel)

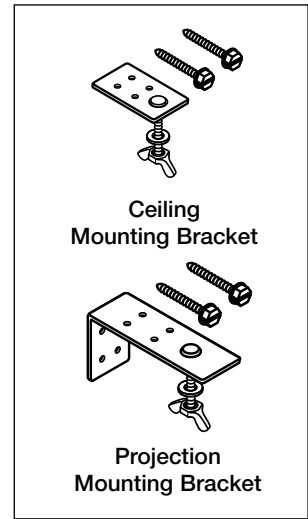

Optional Installation Brackets (available at no additional charge)

Lift Cord
Color-coordinated
1.8mm cord with filler for durability

OPTIONAL: Safety Cord Cleat
Prevents cord from twisting and becoming a strangulation hazard

Wood Tassel
Color-coordinated to the shade

Optional hold-down brackets
Secures bottomrail to door, wall, or window sill; must be specified at time of order

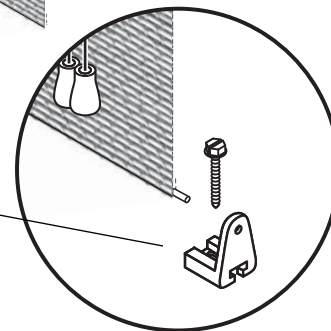

FULL RECESS DEPTH

Type of Mounting Bracket	Standard or Deco-Trim Valances	Traditional Wood Valance	Motorized Lift
Standard and Ceiling Brackets	2½"	3½"	3¾"
Projection brackets	3½"	4 ¹³ / ₁₆ "	4¾"

Natural Shades: Looped Roman Style

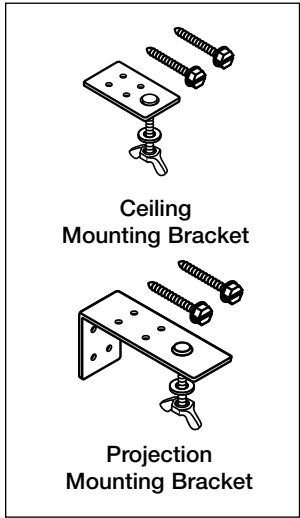
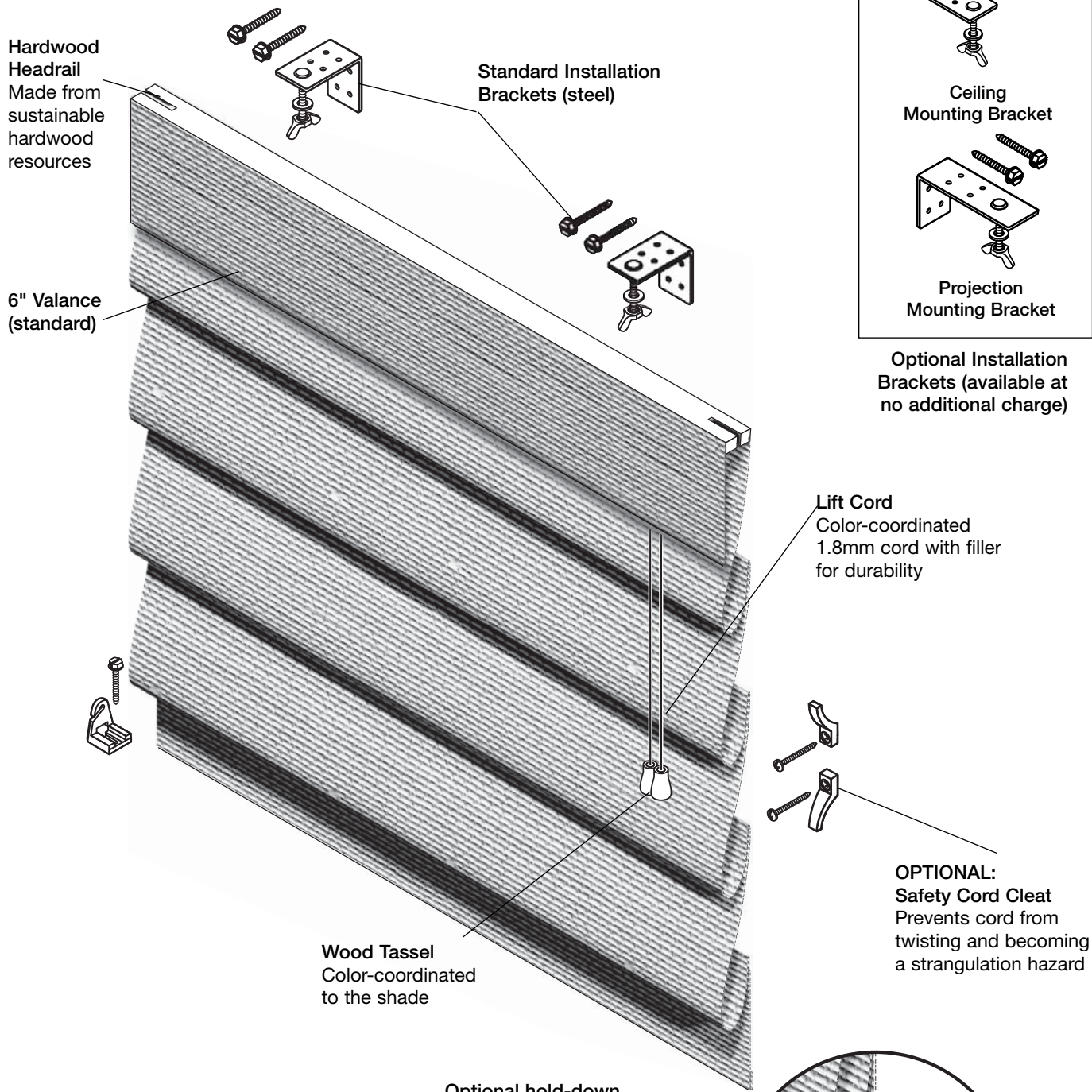

Optional Installation Brackets (available at no additional charge)

Lift Cord
Color-coordinated
1.8mm cord with filler
for durability



OPTIONAL: Safety Cord Cleat
Prevents cord from twisting and becoming a strangulation hazard

Wood Tassel
Color-coordinated to the shade

Optional hold-down device and brackets
Secures bottomrail to door, wall, or window sill; must be specified at time of order

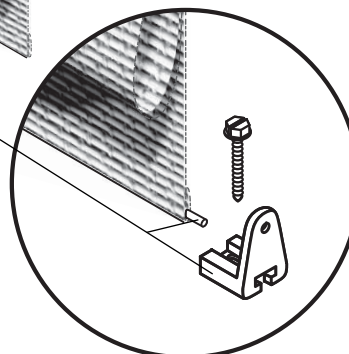

FULL RECESS DEPTH

Type of Mounting Bracket	Standard or Deco-Trim Valances	Traditional Wood Valance
Standard and Ceiling Brackets	2½"	3½"
Projection brackets	3½"	4 ¹³ / ₁₆ "

Natural Shades: Continuous Cord Loop

Hardwood Headrail
Made from sustainable hardwood resources

9" Valance (standard)

Standard Installation Brackets (Steel)

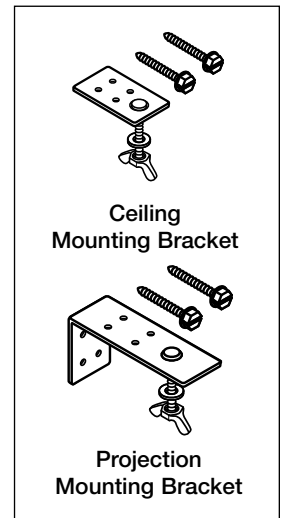

Optional Installation Brackets (available at no additional charge)

Continuous Loop
Color-coordinated to the shade; length stays consistent regardless of shade height

Tension Device
Prevents cord from twisting and becoming a strangulation hazard

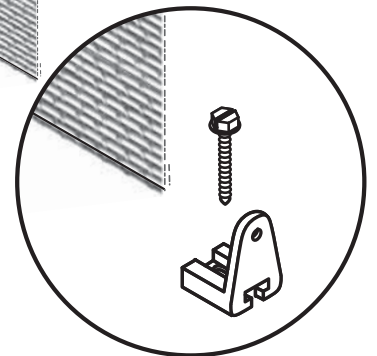

Optional hold-down brackets
Secures bottomrail to door, wall, or window sill; must be specified at time of order

Continuous Cord Loop Features and Benefits:

- Continuous cord loop control cord raises and lowers the shade
- America's #1 continuous clutch draw system by RollEase® allows you to raise or lower the shade smoothly and effortlessly
- Allows for easier operation of larger shades
- Shades over 30 square feet will use a nickel-plated steel bead chain loop in place of cord
- When ordering different size shades for the same room, specify if bead chain is preferred for all shades
- Lift cord is .9mm cord with filler for durability
- The 9" valance is standard with the continuous cord loop option; 6" and wood valance not available
- Not available with motorization or mitered corner shades

FULL RECESS DEPTH

Type of Mounting Bracket	Standard or Deco-Trim Valances
Standard and Ceiling Brackets	3 3/8"
Projection brackets	4 3/8"

Natural Drape: Standard Cord Control

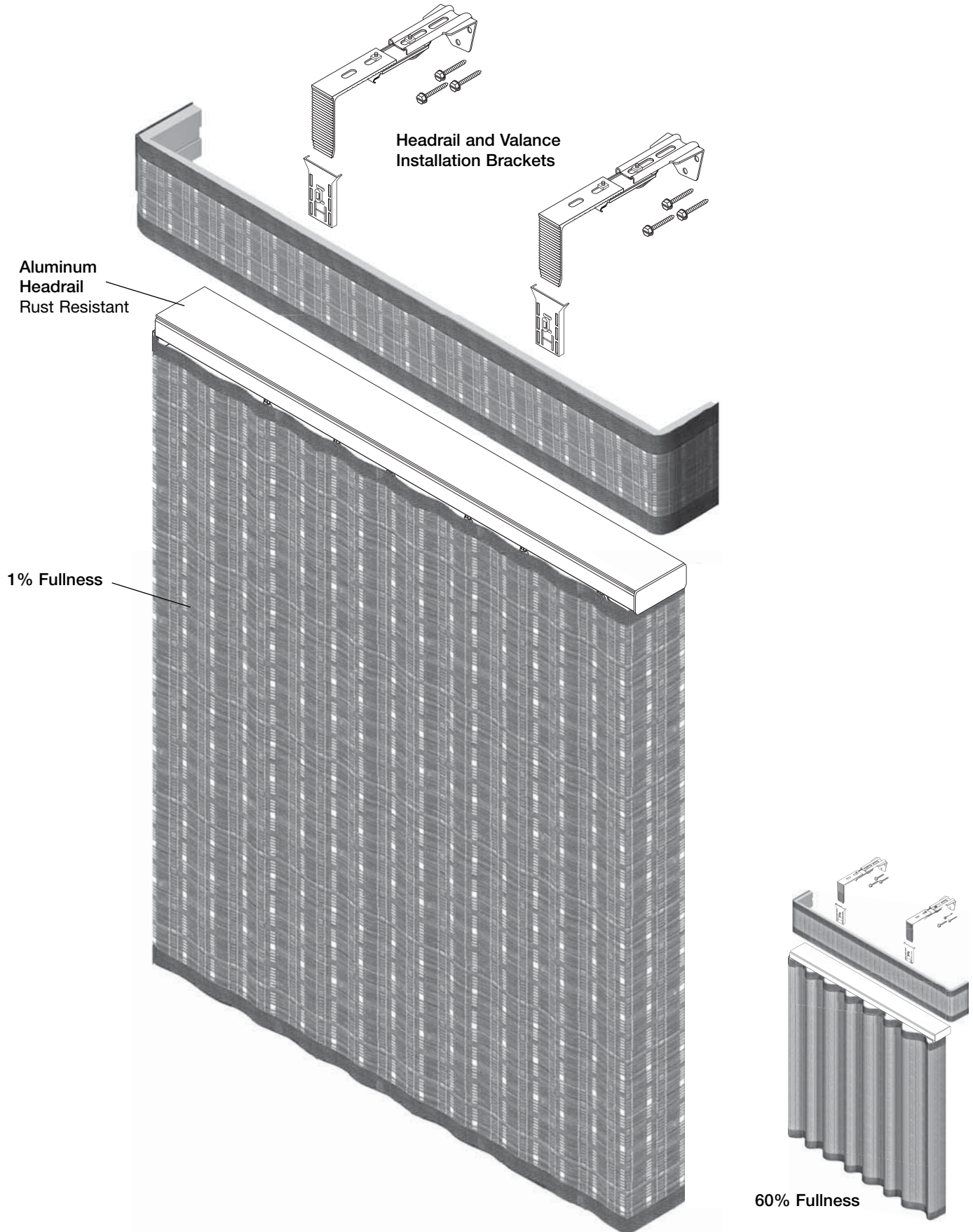

NOTE: Natural materials are vertically oriented on the Natural Drape and Valance.

Natural Drape: Standard Wand Control

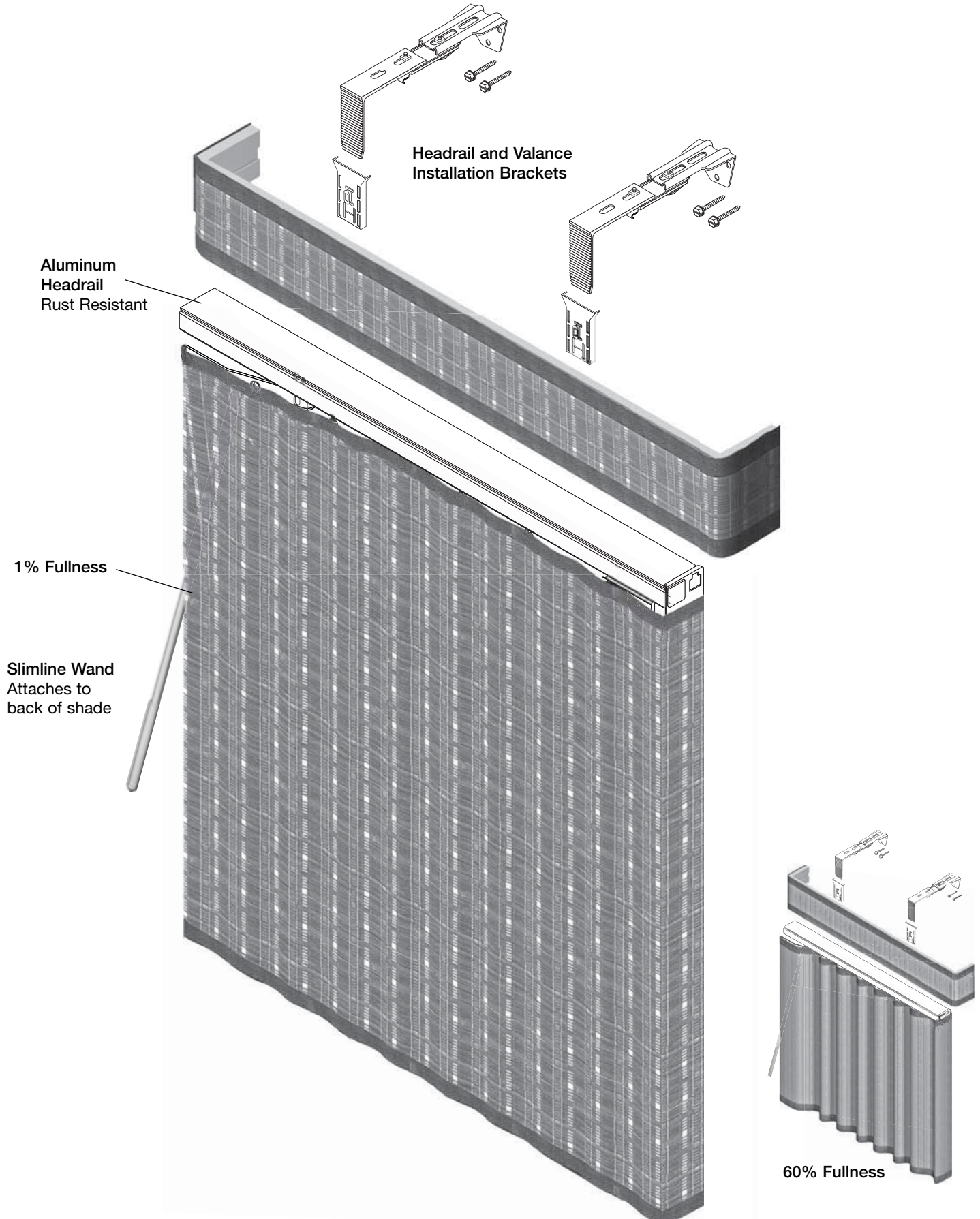

NOTE: Natural materials are vertically oriented on the Natural Drape and Valance.

General Information

Privacy & Room-darkening Liner Color Coordination

Style Name	Color Name	Color Number	Suggested Privacy Liner **	Suggested Room-darkening Liner **
Arima	Ebony	51227	Espresso 0632	Espresso 5632
	Tapestry	51201	Espresso 0632	Espresso 5632
Cabo	Chestnut	06703	Espresso 0632	Espresso 5632
	Chocolate	06793	Chestnut 0297	Chestnut 5297
	Honey Nut	06702	Buff 0093	Buff 5093
	Linden	06701	Espresso 0632	Espresso 5632
	Tortoise	09859	Buff 0093	Buff 5093
Caracas	Abyss	32401	Espresso 0632	Espresso 5632
	Ash	32445	Buff 0093	Buff 5093
	Hazel	32402	Espresso 0632	Espresso 5632
	Honey	32296	Buff 0093	Buff 5093
Cordoba	Natural	32864	Buff 0093	Buff 5093
	Golden	41710	Buff 0093	Buff 5093
Curacao	Beige	21011	Buff 0093	Buff 5093
	Caramelized	21003	Buff 0093	Buff 5093
	Cocoa	21001	Chestnut 0297	Chestnut 5297
	Loden	21002	Buff 0093	Buff 5093
	Whitewash	21298	Soft White 0417	Buff 5093
Fernando	Black Coffee	35716	Espresso 0632	Espresso 5632
	Raisin	35714	Chestnut 0297	Chestnut 5297
Grasses	Beach	28002	Soft White 0417	Buff 5093
	Harvest	28003	Buff 0093	Buff 5093
	Summer	28001	Buff 0093	Buff 5093
Haven	Cabana	25602	Buff 0093	Buff 5093
	Cottage	25601	Chestnut 0297	Chestnut 5297
Jamaica	Black	17156	Buff 0093	Buff 5093
Legends	Aussie	29001	Buff 0093	Buff 5093
	Tuscany	29002	Chestnut 0297	Chestnut 5297
Maracaibo	Nutshell	27402	Espresso 0632	Espresso 5632
	Spice	27685	Chestnut 0297	Chestnut 5297
Margarita	Umber	40263	Buff 0093	Buff 5093
Montego	Cherry	61655	Buff 0093	Buff 5093
Nassau	Cedar	53086	Buff 0093	Buff 5093
	Clay	53083	Chestnut 0297	Chestnut 5297
	Nutshell	53084	Chestnut 0297	Chestnut 5297
Nicaragua	Chocolate	63759	Chestnut 0297	Chestnut 5297
	Umber	63659	Buff 0093	Buff 5093
Resonance	Mahogany	00003	Chestnut 0297	Chestnut 5297
	Tiger	00001	Chestnut 0297	Chestnut 5297
Retreat	Gold	11501	Buff 0093	Buff 5093
	Ivory	11503	Soft White 0417	Buff 5093
	White	11502	Soft White 0417	Buff 5093
San Pedro	Umber	24864	Buff 0093	Buff 5093
Tobago	Tranquil	26877	Buff 0093	Buff 5093
Trinidad	Deep Cherry	60845	Chestnut 0297	Chestnut 5297
	Whitewash	60417	Soft White 0417	Buff 5093
Valera	Cordovan	34587	Buff 0093	Buff 5093

****NOTE:** The Privacy Liner is colored front and back. Please order Soft White if a neutral color is needed facing the street. All colors of the Room-darkening Liner are white facing the street.

Fabric Content

Arima	Bamboo Reed, Grasses, Jute Braid	Sheer to Light Filtering	Same front and back
Cabo	Slit Bamboo, Bamboo Reed	Sheer to Light Filtering	Same front and back
Caracas	Bamboo Reed	Sheer to Light Filtering	Same front and back
Cordoba	Slit Bamboo, Bamboo Reed, Jute Rope	Sheer	Same front and back
Curacao	Bamboo Reed	Sheer	Same front and back
Fernando	Slit Bamboo, Bamboo Reed, Jute Rope	Sheer to Light Filtering	Same front and back
Grasses	Grasses	Light Filtering	Same front and back
Haven	Bamboo Reed	Light Filtering	Same front and Back
Jamaica	Bamboo Slat, Bamboo Reed	Light Filtering	Same front and back
Legends	Bamboo Reed, Cellulose	Sheer to Light Filtering	Same front and back
Maracaibo	Bamboo Reed	Light Filtering	Same front and back
Margarita	Bamboo Reed, Hollow Bamboo, Jute Braid	Sheer to Light Filtering	Same front and back
Montego	Slit Bamboo, Bamboo Reed	Sheer	Same front and back
Nassau	Bamboo Reed, Grasses, Jute Rope	Sheer to Light Filtering	Same front and back
Nicaragua	Slit Bamboo, Bamboo Reed	Light Filtering	Same front and back
Resonance	Slit Bamboo, Bamboo Reed, Curly Jute	Light Filtering	Same front and back
Retreat	Bamboo Reed	Light Filtering	Same front and back
San Pedro	Slit Bamboo, Bamboo Reed, Grass Rope	Sheer to Light Filtering	Same front and back
Tobago	Bamboo Slat	Light Filtering	Same front and back
Trinidad	Bamboo Slat, Bamboo Reed	Sheer to Light Filtering	Same front and back
Valera	Slit Bamboo, Bamboo Reed, Grass Rope	Light Filtering	Same front and back

NOTE: Increase privacy with optional privacy or Room-darkening liner.

Warranty

Warranty Information

Type of Warranty

Limited Lifetime on

- Natural Shades, Roller Shades, Solar Shades, Roman Shades, Cellular Shades, Pleated Shades, Sliding Panels and painted or stained cornices (unfinished cornices are not warranted).

Three year on

- Standard Pleat products.

What is Covered

This product is warranted against original defects in materials or workmanship for as long as the original purchaser owns the product provided that:

1. the product was properly installed in a residential dwelling;
2. the product was made or assembled exclusively from Springs Window Fashions materials and components;
3. Springs Window Fashions recommendations were followed with regard to limitations and specifications.

Who is Covered

This warranty extends only to you as the original purchaser of the above stated product.

Obligations to the Consumer

The obligations of Springs Window Fashions are limited to the repair or replacement of parts or products found to be defective.

Springs Window Fashions is not responsible for shipping costs or labor costs, for measuring and taking the product down or for remeasuring or reinstalling the product.

If repairs are made under this warranty, the repairs will be made with like or similar parts.

Motorization

Components and accessories have a five-year limited warranty. Batteries not included.

What the Warranty Does Not Cover

This warranty does not cover conditions or damages caused by abuse, accidents, alterations, misuse or failure to follow instructions for measurement, installation, use, cleaning or maintenance. Normal wear and tear, including but not limited to the items or occurrences below, is not covered by the warranty.

- Unfinished cornices
- All fabrics can lose original intensity after long exposure to the sun
- When left for extended periods in direct sunlight, plastics tend to yellow or crack
- Some loss of color intensity or discoloration may occur in plastic materials or wood finishes when exposed to direct sunlight over long periods of time
- Colors may vary from lot to lot and may not exactly match samples of previous purchases
- All cords will eventually wear out

Springs Window Fashions considers these items or occurrences normal wear and tear and they are not covered by this warranty.

THIS WARRANTY IS EXCLUSIVE AND IN LIEU OF ALL OTHER WRITTEN OR ORAL WARRANTIES OR OBLIGATIONS AND LIABILITIES.

No person is authorized to extend or alter this warranty.

SPRINGS WINDOW FASHIONS SHALL HAVE NO LIABILITY WHATSOEVER FOR INCIDENTAL OR CONSEQUENTIAL DAMAGES.

Some states do not allow the exclusion or limitation of incidental or consequential damages, so this limitation or exclusion may not apply to you.

Service

Warranty claims must be accompanied by the original sales receipt as well as details regarding the nature of the problem, location of the product, etc. To obtain warranty service contact:

Customer Service Center
Springs Window Fashions, LLC
8467 Route 405 Highway South
PO Box 500
Montgomery, PA 17752-0500

You may also email [windowfashions@springswindowfashions.com](mailto>windowfashions@springswindowfashions.com) or call 1-800-221-6352.



For additional Bali products, go to www.baliblinds.com

BALI® is a brand of
SPRINGS WINDOW FASHIONS
the Best Experience Company